

# Tridak® Model 3200 User Guide

---

## Piston Inserter

- Instructions for Safe Use
- Setup and Operation
- Maintenance
- Ordering Spare Parts & Accessories

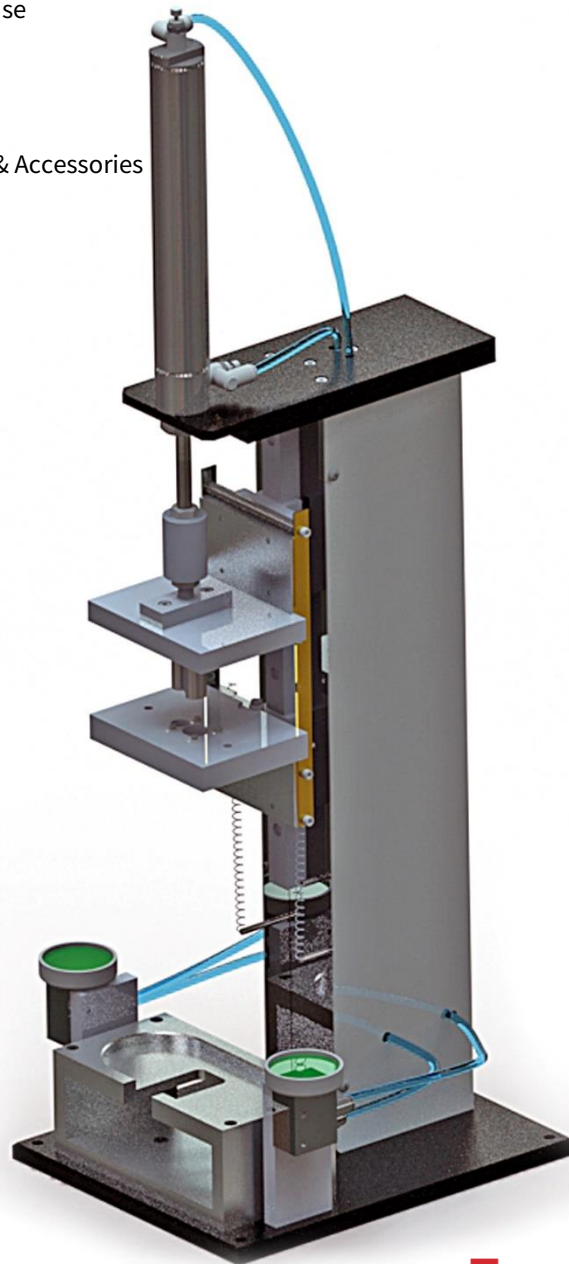

**tridak®**

## **About Tridak**

### **Systems for fluid packaging.**

Tridak manufactures fluid packaging systems for a variety of industries including industrial, medical, dental, pharmaceutical, and food preparation. Tridak's filling systems for syringes and cartridges provide significant productivity gains over manual and other more complicated and costly filling methods. The equipment is suited for all industry standard packaging as well as custom molded syringes and cartridges. Tridak possesses the capability to fabricate nozzles and multi-port dispensing manifolds that perfectly match the packages being filled. Single- and dual-component materials can be packaged in seconds, one at a time, or in multiples for higher volume throughput. The equipment accommodates various mix ratios. High-pressure filling equipment is available for packaging highly filled materials in tiny syringes or compoules.

Please note that most filling system applications are unique. Tridak does not warrant the fitness of the product for the intended application. Any warranty applicable to the product, its application and use is strictly limited to that contained in the Tridak standard Conditions of Sale. Tridak recommends that any intended application be evaluated and tested by the user to insure that desired performance criteria are satisfied. Tridak is willing to assist users in their performance testing and evaluation. Data sheets are available for pressure pots upon request.

# Contents

<b>Introduction .....</b>	<b>4</b>
Introduction to the User Guide.....	4
Where to Get Help.....	4
<b>Safety .....</b>	<b>4</b>
General Safety Considerations .....	4
Specific Safety Considerations .....	4
Potential Hazards .....	5
<b>Product Overview .....</b>	<b>5</b>
Description of the Tridak Piston Inserter .....	5
Special Features and Benefits of the Tridak Piston Inserter .....	5
Description of Main Components .....	6
<b>Assembly and Setup .....</b>	<b>7</b>
Unpacking and Inspecting Your Shipment .....	7
Utilities Required .....	7
Parts Included in the Model 3200 Piston Inserter.....	7
<b>Preparing the System for Use.....</b>	<b>7</b>
Mounting .....	7
System Interconnect .....	8
<b>Operating the System .....</b>	<b>8</b>
Operation .....	8
<b>System Adjustments .....</b>	<b>9</b>
The Effect of Air Pressure .....	9
Adjusting the Depth of Insertion.....	9
Adjusting the Stroke Speed .....	9
Adjusting the Return Speed .....	9
<b>Maintenance and Cleaning.....</b>	<b>10</b>
General .....	10
Replacing Air Bleed Wires .....	10
Replacing the Tooling .....	11
<b>Spare Parts and Accessories.....</b>	<b>11</b>
Custom Replacement Parts .....	12
<b>Specifications.....</b>	<b>13</b>
<b>Warranty.....</b>	<b>14</b>
<b>Index .....</b>	<b>15</b>

# Introduction

## Introduction to the User Guide

This guide describes how to assemble, use, and maintain the Tridak® Model 3200 Piston Inserter safely and efficiently.

## Intended Audience

We prepared this user guide for experienced process engineers, technicians, and manufacturing personnel. If you are new to filling systems and do not understand the instructions, contact Dymax Application Engineering to answer your questions before using the equipment.

## Where to Get Help

Additional resources are available to ensure a trouble-free experience with our products:

- Detailed product information on [www.tridak.com](http://www.tridak.com)
- Customer Support and Application Engineering teams are available in the United States, Monday through Friday, from 8:00 a.m. to 5:30 p.m. Eastern Standard Time. You can also email us at [info@tridak.com](mailto:info@tridak.com). Please see the back cover of this user guide for worldwide contact information.

# Safety



**WARNING!** *If you use this filling system without first reading and understanding the information in this user guide, injury can result. To reduce the risk of injury, read and ensure you understand the information in this user guide before assembling and operating a Tridak filling system.*

## General Safety Considerations

All users of Tridak filling equipment should read and understand this user guide before assembling and using the equipment.

## Specific Safety Considerations

### Using Safe Operating Pressures

Pressurizing the components in the packaging system beyond the maximum recommended pressure can result in the rupturing of components and serious personal injury. To minimize the risk of rupturing components and injury, do not exceed the maximum operating pressure of the components in your fluid packaging system (see system specifications on page 12). The maximum working pressure of this system is 100 psi (0.69 Mpa, 6.9 bar).

## Preventing Injection Injury

Discharging fluids or compressed air with a dispensing tip or nozzle against your skin can cause very serious injection injury. To minimize the risk of injection injury, do not place the dispensing tip or nozzle in contact with your skin.

## Personal Protective Equipment

Operators are recommended to wear any personal protective equipment specified by their company's safety policy for the materials used during filling. Personal protective equipment should be in place and used at all times before pressurizing the system and when handling any potentially hazardous materials.

## Potential Hazards

### Equipment Misuse

This equipment is for professional use only. Do not alter this equipment in any way. Check the equipment daily for worn parts. Repair or replace worn or damaged parts immediately and use only Tridak parts.

Comply with all the applicable local, state, and national fire and safety regulations.

# Product Overview

## Description of the Tridak Piston Inserter

The Tridak Piston Inserter allows operators to insert pistons into cartridges and syringe barrels accurately and quickly. With an automatic air-bleed system to eliminate trapped air, and the ability to adjust the insertion depth of the pistons, these machines can be used to seal most syringes and cartridges.

## Special Features and Benefits of the Tridak Piston Inserter

The Tridak piston inserter is engineered for precise performance and long service life. Key features and benefits include:

- Eliminates leaks with accurate, consistent piston insertion
- Cycle time of 1-to-3 seconds
- Adjustable piston insertion depth
- Automatic air-bleed system eliminates trapped air
- Automatic guidance and holding system accurately aligns the cartridge and pistons
- Dual-hand actuation trigger for operator safety

## Description of Main Components

*NOTE: These instructions are generalized to cover all of the tooling types that are used. Every piston inserter comes with specific cartridge tooling. The location and appearance of any component described or shown in any illustrations may vary from those supplied.*

**Figure 1.** Main Components of the Model 3200 Piston Inserter

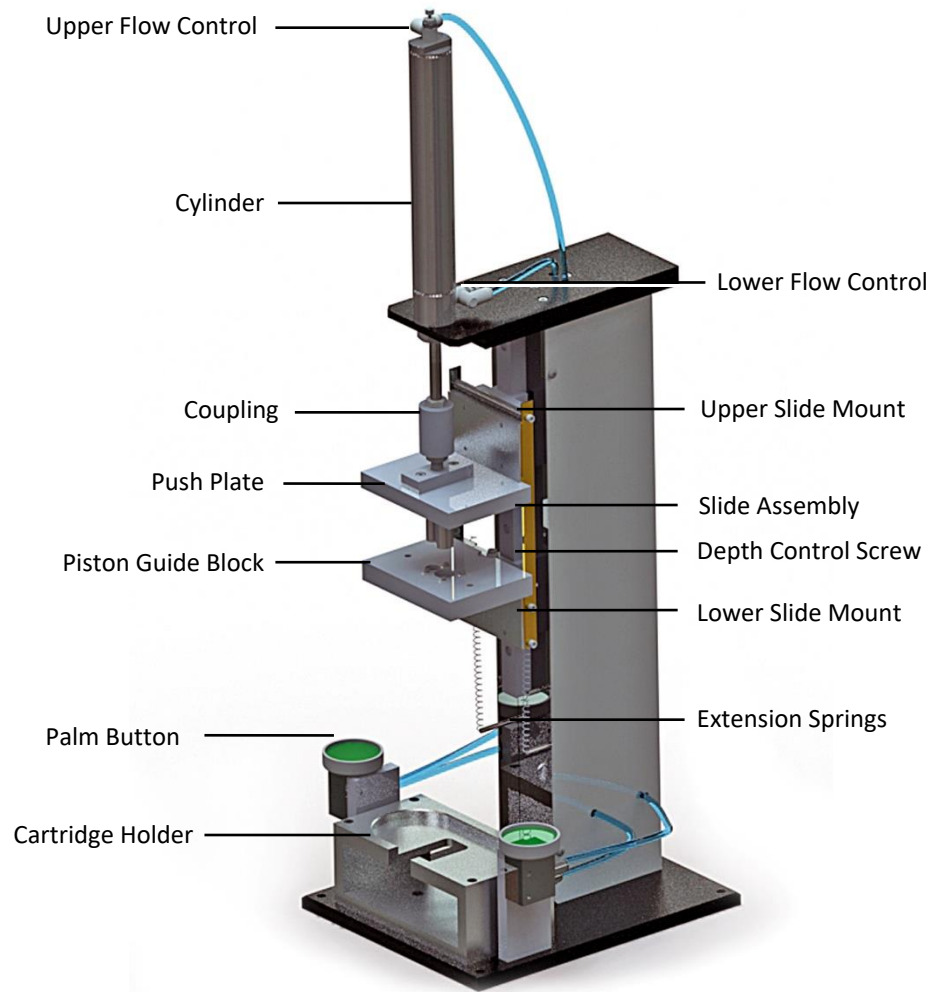

# Assembly and Setup

## Unpacking and Inspecting Your Shipment

When your piston inserter arrives, inspect the boxes for damage and notify the shipper of box damage immediately.

Open each box and check for equipment damage. If parts are damaged, notify the shipper and submit a claim for the damaged parts. Contact Dymax so that new parts can be shipped to you immediately.

The parts listed below will be included in your shipment. If parts are missing, contact your local Dymax representative or Dymax Customer Support to resolve the problem.

### Parts Included in the Model 3200 Piston Inserter

- Model 3200 Piston Inserter
- Custom Tooling (contact Dymax customer support)
- User Guide

## Connections Required

AIR: 60-100 psi (0.41-0.69 Mpa), 50 micron filtered, non-lubricated; dry air is required.

# Preparing the System for Use

## Mounting

Secure the piston inserter to a permanent workbench using four 5/16" [8 mm] diameter bolts. Refer to Figure 2 for the correct pattern and hole size.

*NOTE: It is very important for safety reasons that the system be properly secured to the workbench.*

**Figure 2.** Mounting Hole Patterns

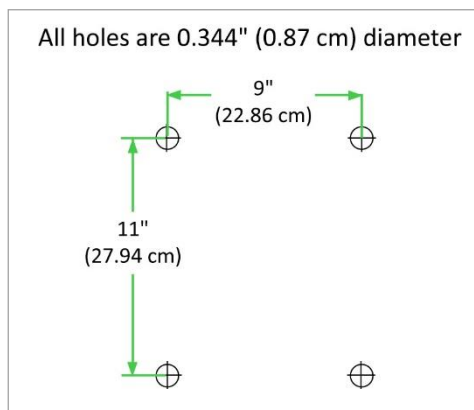

## System Interconnect

1. Connect your shop air to the “Air In” port located at the back of the unit.

*NOTE: The air in port is a “push-in” type fitting that accepts a 1/4" OD air line.*

2. Set the air pressure to approximately 80 psi. Then turn the air to the System On.



**WARNING!** Please stay clear of the system when the air is turned on. The drive cylinder will lift to its start position as soon as air is supplied.

3. The rate at which the tooling descends and ascends has been factory adjusted. If you wish to increase or decrease the speed refer to “Adjusting the Speed”.

# Operating the System

## Operation

1. Place a filled cartridge into the cartridge holder.

*NOTE: Depending on the design of the cartridge being used in this system, the design of the cartridge holder may vary from the figure shown. Some cartridges are located by placing their bottoms into the holder while others are suspended from finger tabs located at their tops.*

2. Place each of the pistons into the piston guide block. The pistons should be placed so that their top surfaces are approximately parallel to the top surface of the guide blocks.

*NOTE: Make sure that the pistons are inserted into the guide block in the correct orientation—refer to the manufacturer’s cartridge instructions or drawings if clarification is required.*

3. Depress and hold the two palm button actuators. The piston guide block will descend and engage the cartridge and the pistons will be inserted.



**WARNING!** The piston inserter will only operate when both palm buttons are pressed at the same time. This assures that the operator’s hands are located in a safe location and are clear from any moving parts. Dymax accepts no responsibility for any injuries that may occur if the two palm button actuation control is not used as intended.

4. When all motion stops, release the palm buttons. The drive cylinder retracts to its start position.

*NOTE: On systems that are equipped with air bleeder wires, the cartridge may be lifted out of the tooling. This is normal. To adjust, trim the wires evenly until the cartridge no longer lifts out of the tooling.*

5. Remove the cartridge from the tooling or pull it free from the bleeder wires.



# System Adjustments

## The Effect of Air Pressure

Air pressure provides the force required to push the pistons into the cartridges. The pressure should be set at the minimum setting necessary to guarantee that the pistons will always be fully inserted into the cartridge. The actual required pressure can only be determined experimentally.

## Adjusting the Depth of Insertion

The adjusting screw on the large inserter is located on the top of the piston guide carriage.

1. Loosen the locknut.
2. Adjust the screw counter clockwise to decrease the insertion into the cartridge.
3. Adjust the screw clockwise to increase the depth of insertion into the cartridge.
4. Retighten the locknut.

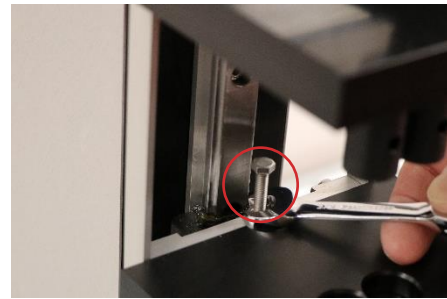

## Adjusting the Stroke Speed

1. Loosen the locknut located on the lower flow control valve by turning it counter clockwise.
2. Slow the insertion rate down by turning the flow control knob clockwise. Increase the rate by turning the knob counter clockwise.
3. Check the speed after each adjustment by depressing the two hand controls and holding them until the stroke is complete. Observe the rate and readjust the flow control valve until the desired rate is achieved.
4. Lock the setting by turning the locknut clockwise until it is firmly seated.

## Adjusting the Return Speed

1. Loosen the locknut located on the upper flow control valve by turning it counter clockwise.
2. Slow the return rate down by turning the flow control knob clockwise. Increase the rate by turning the knob counter clockwise.
3. Check the speed after each adjustment by depressing the two hand controls and holding them until the stroke is complete. Observe the return rate after the two hand controls are released and readjust the flow control valve until the desired rate is achieved.
4. Lock the setting by turning the locknut clockwise until it is firmly seated.

# Maintenance and Cleaning

## General

With the exception of the air bleed wires (if applicable) there are no components that make contact with the material in the cartridges. This allows for a very simple clean up and very little mess. The piston inserter should be wiped clean of any material on a daily basis. The air bleed wires should to be cleaned and any residual material removed as needed during operation.

## Replacing Air Bleed Wires

**(Applies only to systems that insert pistons without vents)**

The air bleed wires are held in place by four screws. To replace the wires, remove the screws and wires and replace with new wires by reversing the disassembly sequence.

**Figure 3.** Air Bleed Wires

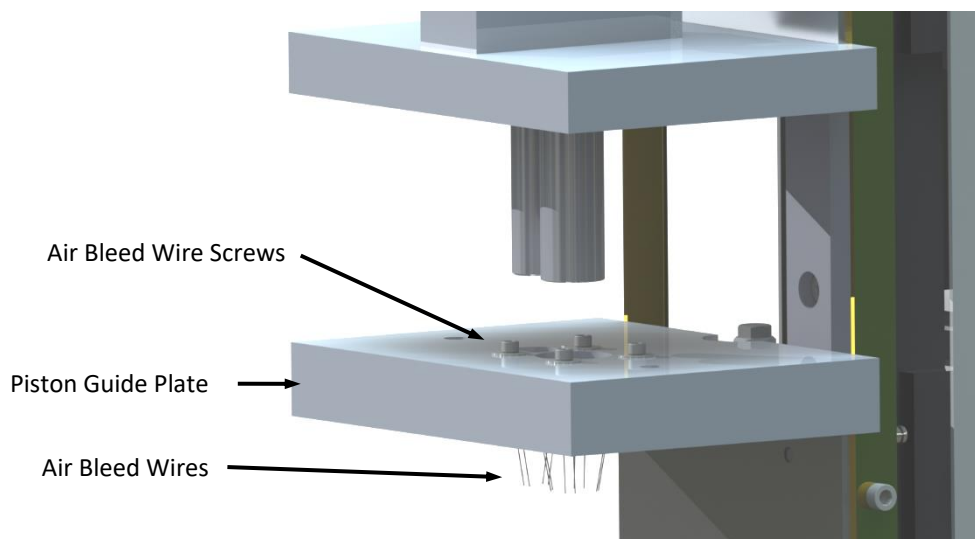

## Replacing the Tooling

1. Remove the socket head cap screws from the rear of the upper slide mount to release the push plate.

*NOTE: There are four screws (two on each side of the system) securing the tooling.*

2. Remove the socket head cap screws from the rear of the lower slide mount to release the piston guide plate.

**Figure 4.** Releasing the Tooling

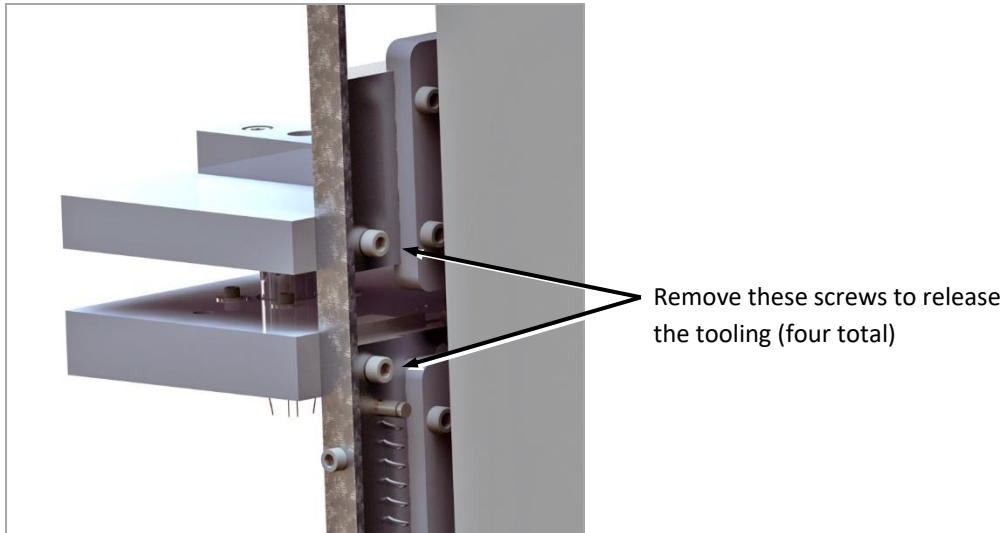

3. Place the tooling block
4. Replace the four socket head cap screws.

# Spare Parts and Accessories

## Custom Replacement Parts

### Tooling

Complete tooling assembly includes: press plate, piston guide plate (complete with air bleed wires if required), cartridge guide (if required), and cartridge holder.

To order, please provide the following information to Dymax customer support:

- Cartridge manufacturer
- Cartridge size (volume per manufacturers' specification)
- Ratio of cartridge
- Samples of cartridge and pistons

*NOTES: If a complete set of tooling is required please specify COMPLETE. If only a specific component of the tooling is required, please specify the name of the component(s) per Figure 1 and the above information.*

*Due to the revisions that the manufacturers of the cartridges make to their products, it is important to include three samples of both the cartridges and the pistons with each order unless this requirement has been waived by Dymax.*

# Specifications

Property	Specification
<b>Part Numbers</b>	<b>T10105</b> Piston Inserter
<b>Operating Air Pressure</b>	60 psi (4.83 bar) min / 100 psi (6.89 bar) max
<b>Dimensions (L x W x H)</b>	10" x 12" x 36" (25.4 cm x 30.48 cm x 91.44 cm)
<b>Compatible Sizes</b>	Cartridges and syringe barrels up to 500 mL Maximum cartridge height: 7" (18 cm) Maximum cartridge/piston diameter: 2.5" (6.5 cm)
<b>Unit Warranty</b>	1 year from purchase date



# Warranty

From date of purchase, Dymax offers a one-year warranty against defects in material and workmanship on all system components with proof of purchase and purchase date. Unauthorized repair, modification, or improper use of equipment may void your warranty benefits. The use of aftermarket replacement parts not supplied or approved by Dymax, will void any effective warranties and may result in damage to the equipment.

**IMPORTANT NOTE:** DYNAMX RESERVES THE RIGHT TO INVALIDATE ANY WARRANTIES, EXPRESSED OR IMPLIED, DUE TO ANY REPAIRS PERFORMED OR ATTEMPTED ON DYNAMX EQUIPMENT WITHOUT WRITTEN AUTHORIZATION FROM TRIDAK. THOSE CORRECTIVE ACTIONS LISTED ABOVE ARE LIMITED TO THIS AUTHORIZATION.

# Index

- Air Connections, 8
- Assembly
  - Utilities, 7
- Assembly and Setup, 7
- Cleaning, 10
- Compressed Air Requirements, 7
- Depth of Insertion Adjustment, 9
- Description of System Components, 6
- Help, 4
- Maintenance, 10
- Optional Equipment, 12
- Parts Included, 7
- Product Overview, 5
- Replacement Parts, 12
- Replacing Air Strips, 10
- Replacing Tooling, 11
- Return Speed Adjustment, 9
- Safety, 4
  - Personal Protective Equipment, 5
  - Potential Hazards, 5
  - Preventing Injection Injury, 5
  - Using Safe Operating Pressures, 4
- Spare Parts and Accessories, 12
- Specifications, 13
- Stroke Speed Adjustment, 9
- Support, 4
- System Adjustments, 9
- System Benefits, 5
- System Features, 5
- System Interconnect, 8
- System Operation, 8
- Utilities, 7
- Warranty, 14



Tridak LLC | 318 Industrial Lane, Torrington, CT 06790 USA | 860.626.6700 | info@tridak.com | www.tridak.com

---

© 2013-2022 Tridak LLC. All rights reserved. All trademarks in this guide, except where noted, are the property of, or used under license by Tridak LLC.

**Please note that most filling and repackaging system applications are unique.** Tridak does not warrant the fitness of the product for the intended application. Any warranty applicable to the product, its application and use is strictly limited to that contained in Tridak's standard Conditions of Sale. Tridak recommends that any intended application be evaluated and tested by the user to ensure that desired performance criteria are satisfied. Tridak is willing to assist users in their performance testing and evaluation. Data sheets are available for pressure pots upon request.

T17825 TMAN 3/22/2023