

Tridak[®] Model 1050 User Guide

Syringe Filling System

- Instructions for Safe Use
- Setup and Operation
- Maintenance
- Ordering Spare Parts and Accessories

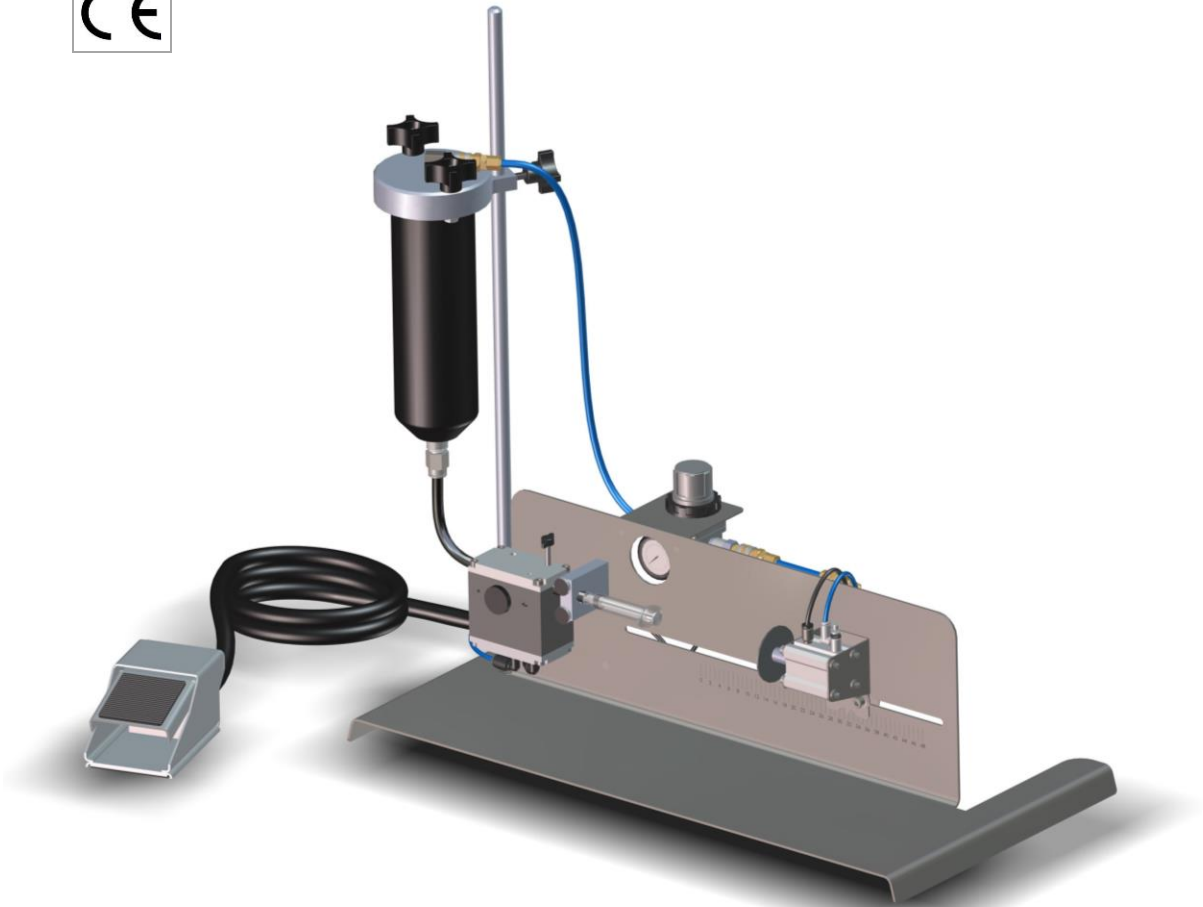

tridak[®]

About Tridak

Systems for fluid packaging.

Tridak manufactures fluid packaging systems for a variety of industries including industrial, medical, dental, pharmaceutical, and food preparation. Tridak's filling systems for syringes and cartridges provide significant productivity gains over manual and other more complicated and costly filling methods. The equipment is suited for all industry standard packaging as well as custom molded syringes and cartridges. Tridak possesses the capability to fabricate nozzles and multi-port dispensing manifolds that perfectly match the packages being filled. Single- and dual-component materials can be packaged in seconds, one at a time, or in multiples for higher volume throughput. The equipment accommodates various mix ratios. High-pressure filling equipment is available for packaging highly filled materials in tiny syringes or compoules.

Please note that most filling system applications are unique. Tridak does not warrant the fitness of the product for the intended application. Any warranty applicable to the product, its application and use is strictly limited to that contained in the Tridak standard Conditions of Sale. Tridak recommends that any intended application be evaluated and tested by the user to insure that desired performance criteria are satisfied. Tridak is willing to assist users in their performance testing and evaluation. Data sheets are available for pressure pots upon request.

Contents

Introduction	4
Introduction to the User Guide.....	4
Where to Get Help.....	4
Safety	4
General Safety Considerations	4
Specific Safety Considerations	4
Personal Protective Equipment.....	5
Product Overview	5
Description of the Model 1050 Syringe Filling System	5
Special Features and Benefits of the Model 1050.....	5
Description of Main Components	6
Assembly and Setup	7
Unpacking and Inspecting Your Shipment	7
Parts Included in the Model 1050 Syringe Filling System	7
Utilities Required	7
Preparing the System for Use	8
Install the Reservoir Support.....	8
Install the Material Reservoir	8
Connect the Material Reservoir Pressure Supply Tube.....	9
Operation	10
Preparing the Cartridge.....	10
Loading the System	11
Pressurizing the System.....	14
Depressurizing the System	14
Set the Fill Amount for the Syringe Size.....	14
Priming the System	15
Prepare the Syringes	15
Fill the Syringe	15
Model 830 Valve Adjustments.....	16
Cleaning and Maintenance	16
System Cleaning	16
Spare Parts and Accessories	18
Replacement Parts/Accessories	18
Specifications	19
System Specifications	19

Introduction

Introduction to the User Guide

This guide describes how to assemble, use, and maintain the Model 1050 Syringe Filling System filling system safely and efficiently.

Intended Audience

We prepared this user guide for experienced process engineers, technicians, and manufacturing personnel. If you are new to filling systems and do not understand the instructions, contact Tridak Application Engineering to answer your questions before using the equipment.

Where to Get Help

Additional resources are available to ensure a trouble-free experience with our products:

- Detailed product information on www.tridak.com
- Customer Support and Application Engineering teams are available in the United States, Monday through Friday, from 8:00 a.m. to 5:30 p.m. Eastern Standard Time. You can also email us at info@tridak.com. Please see the back cover of this user guide for worldwide contact information.

Safety



WARNING! *If you use this filling system without first reading and understanding the information in this user guide, injury can result. To reduce the risk of injury, read and ensure you understand the information in this user guide before assembling and operating a Tridak filling system.*

General Safety Considerations

All users of Tridak equipment should read and understand this user guide before assembling and using the equipment.

Specific Safety Considerations

Using Safe Operating Pressures

Pressurizing the components in the dispensing system beyond the maximum recommended pressure can result in the rupturing of components and serious personal injury. To minimize the risk of rupturing components and injury, do not exceed the maximum operating pressure of the components in your filling system. (See system specifications on page 19)

Preventing Injection Injury

Discharging fluids or compressed air with a dispensing tip against your skin can cause very serious injection injury. To minimize the risk of injection injury, do not place the dispensing tip in contact with your skin.

Personal Protective Equipment

Operators are recommended to wear any personal protective equipment specified by their company's safety policy for the materials used during filling. Personal protective equipment should be in place and used at all times before pressurizing the system and when handling any potentially hazardous materials.

Product Overview

Description of the Model 1050 Syringe Filling System

The Model 1050 syringe filling system is designed to quickly fill plunger-style syringes, one at a time, quickly and accurately from a material reservoir. The system can be used with a number of different material reservoirs including cartridge reservoirs, bottle reservoirs, and pail reservoirs. The system utilizes a Model 830 disposable fluid path valve to make material changeover fast and easy, while eliminating most cross-contamination. The disposable fluid path can be fitted with a series of adapters to fill Luer-Lock and Oral tip syringe types.

Special Features and Benefits of the Model 1050

This machine features several design features to make filling simple, quick and clean, including:

- Disposable fluid path valve with disposable wetted parts that eliminate material contamination and minimize clean-up and maintenance
- Disposable fluid path can be capped and remain attached to the material cartridge for storage
- Adjustable suck-back feature allows for a clean dispense of stringy and tacky materials
- Material reservoir pressure regulator to control the reservoir pressure used for filling
- Fills various syringes including 0.5, 1, 3 and 5 ml (up to 60 ml) syringes with pre-inserted plunger; tooling nozzles are available for both Luer Lock or Oral tips.
- Adjustable pneumatic stop assures accurate fills
- Foot-switch for hands-free fill cycle activation
- Small footprint; Dimensions (L x W x H) – 23.6 in x 12 in x 25 in (60 cm x 30.48 cm x 63.50 cm)

Description of Main Components

The main components in the Model 1050 Syringe Loader filling system include:

1. **Air Regulator** – The air regulator enables you to precisely control the air pressure in the fluid reservoir. The air precision regulator includes:
 - a. Pressure gauge that displays the pressure in the fluid reservoir. A 0- to 100-psi (0- to 6.9-bar) pressure gauge is installed on the air regulator.
 - b. Pressure control knob that enables you to adjust the pressure of the air entering the reservoir. 5-60 psi recommended for most applications.
2. **Compressed Air Line** – The air line consists of blue polyurethane tubing designed for compressed air use.
3. **Model 830 Valve** – A disposable fluid path valve used to dispense material from the material reservoir. This valve features suck-back, allowing drip-free dispensing from fill-to-fill.
4. **Fluid Path** – The fill tube and fittings used to deliver fluid material from bulk cartridges to syringes. It is constructed of black, light-blocking polyethylene tubing compatible with many types of commercial and medical fluids.
5. **Tube Support** – Supports the disposable fluid path during dispensing and allows the valve pistons to compress the fluid path as needed to control fluid flow and suck-back.
6. **Reservoir Retainer or Reservoir Tank** – The reservoir retainers and tanks hold fluid reservoirs. Reservoir retainers accept cartridge reservoirs. Reservoir tanks accept bottle and pail reservoirs.

Figure 1. Main Components of the Model 1050 Syringe Filling System

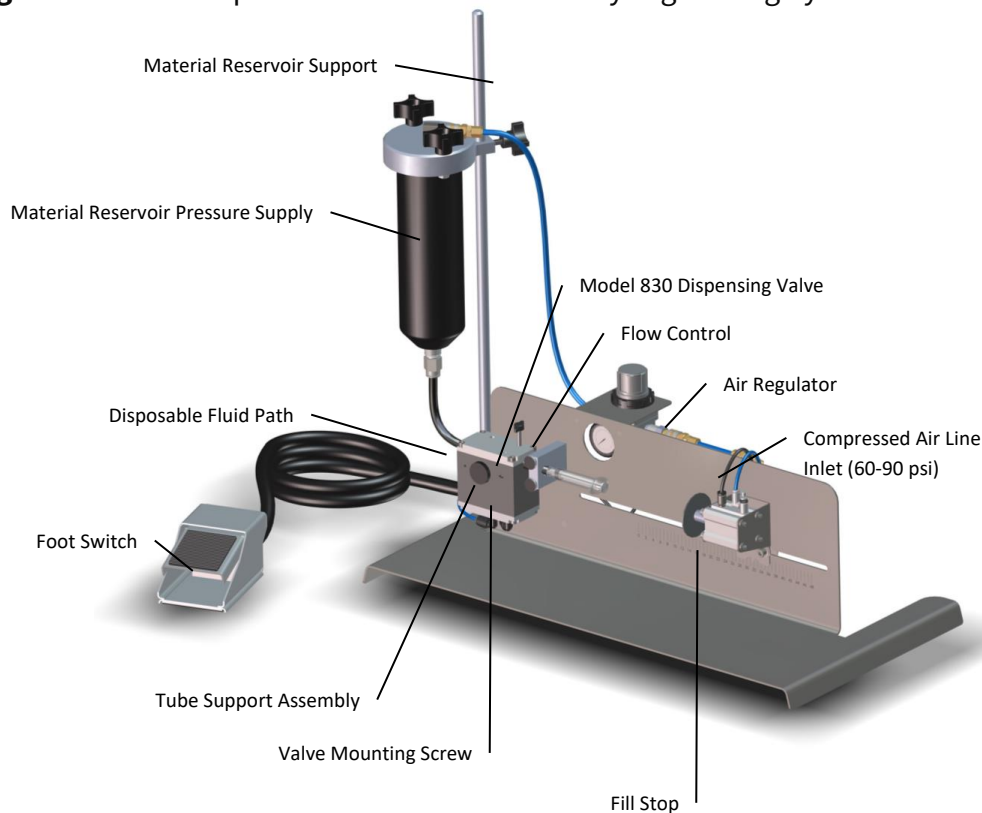

Assembly and Setup

Unpacking and Inspecting Your Shipment

When your system arrives, inspect the boxes for damage and notify the shipper of box damage immediately.

Open each box and check for equipment damage. If parts are damaged, notify the shipper and submit a claim for the damaged parts. Contact Tridak so that new parts can be shipped to you immediately.

The parts listed below will be included in your shipment. If parts are missing, contact your local Tridak representative or Tridak Customer Support to resolve the problem.

Parts Included in the Model 1050 Syringe Filling System

- Model 1050 with Foot Switch [1]
- Tube Assemblies – Luer Female [2]
- Reservoir [3]
- Rod Assembly [4]
- Airline Kit for Reservoir and Model 1050 [5 & 6]
- Allen Key Kit [7]
- 0.32" Bleed Wire with Pull Ring [8]
- Model 1050 User Manual [9]
- Stopper Pin (for use with plunger-less syringes) [Not Shown]

Figure 2. Unpacking Diagram

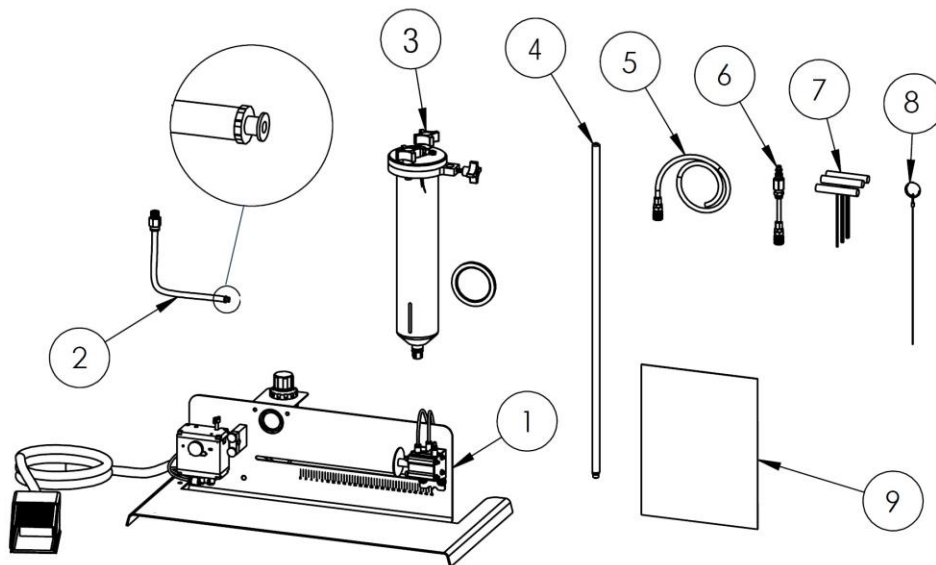

Utilities Required

AIR: Clean, dry, non-lubricated air operating pressure of 60 – 90 psi

Preparing the System for Use

Install the Reservoir Support

1. Place the reservoir support on top of the screw hole in the left side of the system base.
2. Using the screw and washer provided, place screw up with the washer through hole in base and attach to reservoir support. Tighten the screw until the reservoir support is secure (Figure 3).

Figure 3. Reservoir Support Installation

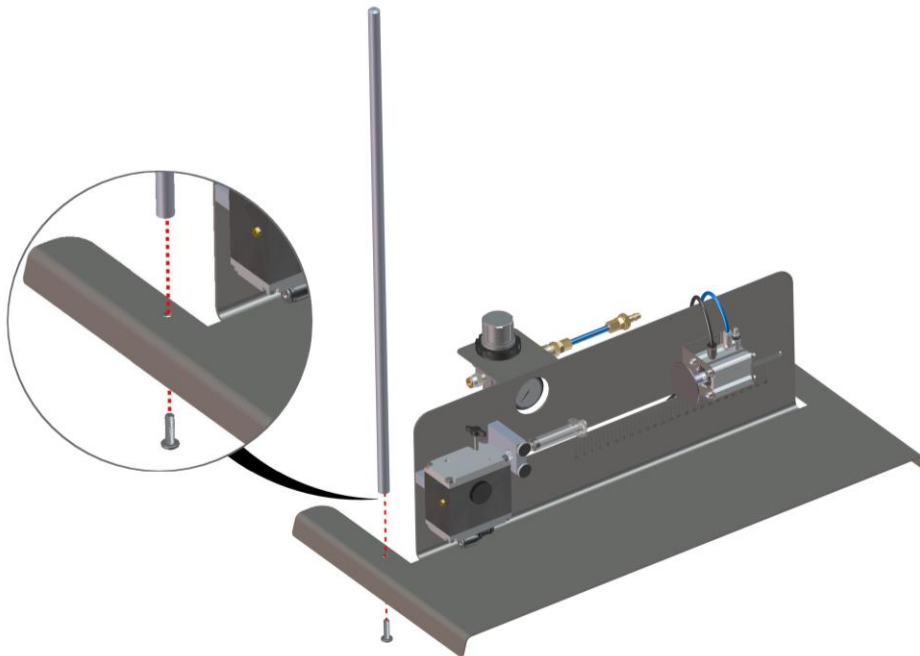

Install the Material Reservoir

1. Slide the Material Reservoir Retainer (Figure 4, D) over the top of the Reservoir Support (Figure 4, B).
2. Position the Material Reservoir Retainer on the Reservoir Support so that the bottom of the Retainer is approximately 2 inches above the top of the Back Plate.
3. Using the Height Adjustment Handle (Figure 4, C), tighten the set screw until the Material Reservoir Retainer does not move.

Connect the Material Reservoir Pressure Supply Tube

1. Connect the material reservoir's Pressure Supply (Figure 4, F) to the Air Regulator (Figure 4, G).
2. Connect the opposite end of the Material Reservoir Pressure Supply to the Material Reservoir Air Inlet.

NOTE: If your system is using a cartridge retainer, the Material Reservoir Air Inlet (Figure 4, A) is located in the center of the cartridge retainer's cap.

Figure 4. Syringe Filler with 20 oz Cartridge Retainer (Rear View)

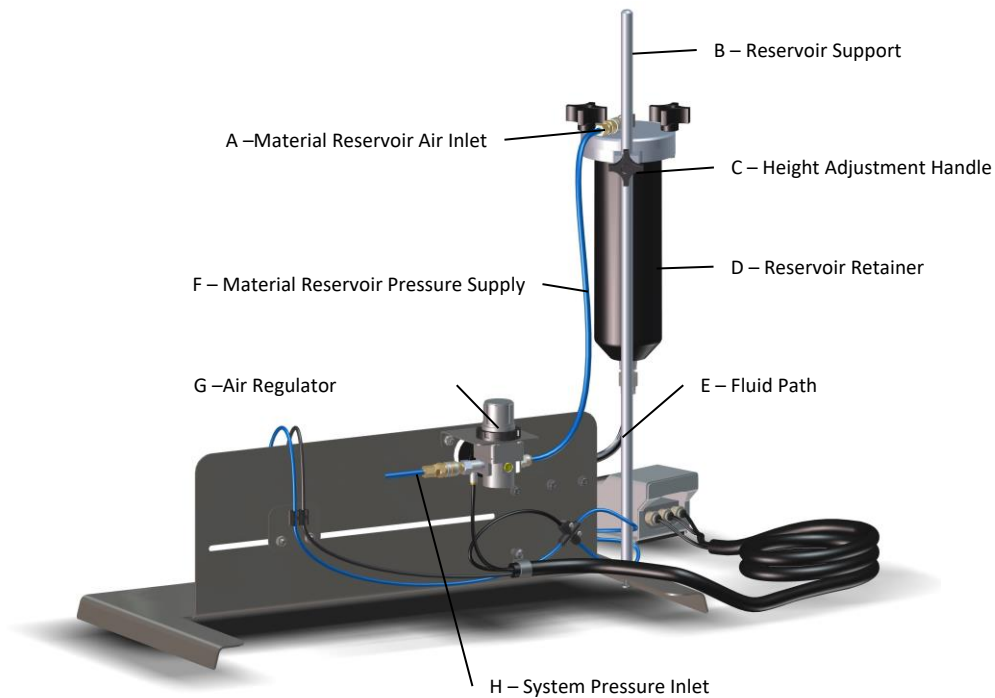

Operation

Preparing the Cartridge

1. Place pre-packaged, sealed cartridge upright on a flat, stable working surface (Figure 5).
2. With the Nozzle up, remove the Colored Cap, and quickly insert the Mating Fitting from the Disposable Fluid Path (Figure 6). Tighten firmly.
3. Ensure the Fluid Path is sealed with a Luer Fitting and Cap before transporting or loading the Cartridge into the Reservoir Retainer.

NOTE: Low-viscosity fluids may require PTFE wrap on threads.

Figure 5. Cartridge with Cap Installed



Figure 6. Cartridge with Fluid Path Installed

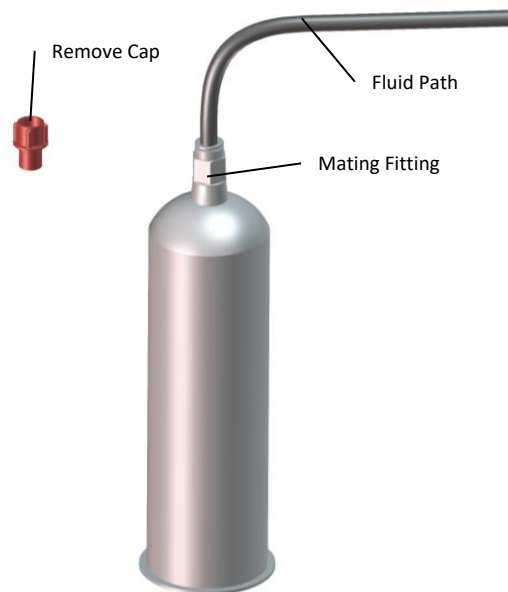

Loading the System

Fill Material Reservoir

1. Remove the Reservoir Retainer Cover by removing the Star Nuts and Cover. Ensure the Retainer is free and clear of any previously placed cartridges or packaging.
2. Insert the Cartridge/Fluid Path Assembly into the Reservoir Retainer.
3. Guide the Fluid Path downward, passing through the bottom of the Reservoir.
4. Press the Cartridge firmly into place until seated.
5. Replace the Reservoir Retainer Cover and tighten evenly and securely with Star Nuts until the Cover forms a solid seal around the Cartridge.

If you experience any trouble, please contact Tridak Customer Service.

Figure 7. Material Reservoir Exploded Diagram

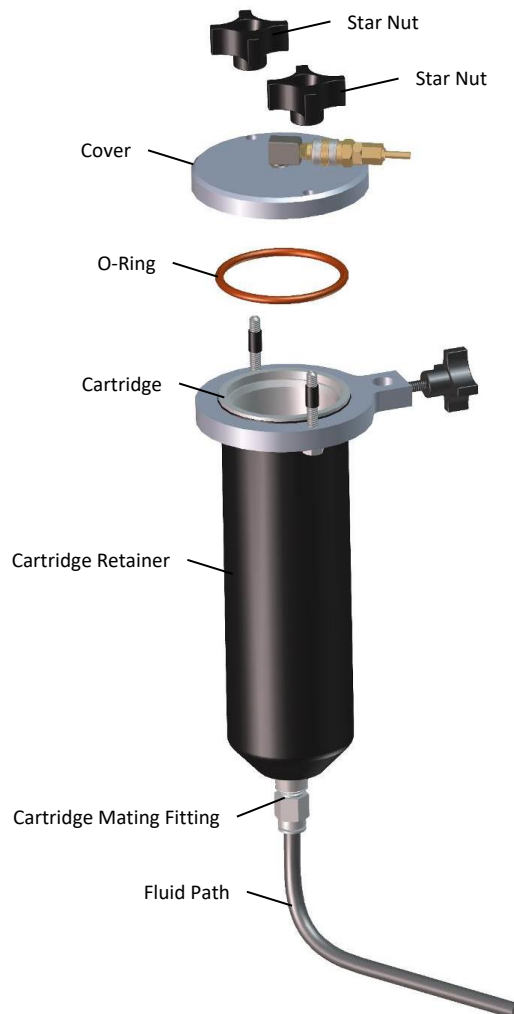

Install the Fluid Path

1. Remove the four 8-32 x 0.75" Screws (Figure 9) that hold the Tube Support and the Valve Body together.
2. Evenly loosen the two Luer Block Clamp Screws (Figure 8) enough to slip the Luer Tip Cap through the opening. Position the Fluid Path in the Luer Block Clamp so that the left edge of the Luer Block Clamp just catches the white Luer Tip.
3. Evenly tighten the two Luer Block Clamp Screws.
4. Install the Fluid Path and the Tube Support to the Model 830 Valve (Figure 8). The Tube Support has two access holes for the over-pinch and suck-back adjusts at the top of the cover and must be installed in the correct orientation. Evenly tighten the two Tube Support Removal Screws.

Figure 8. Luer Block Clamp

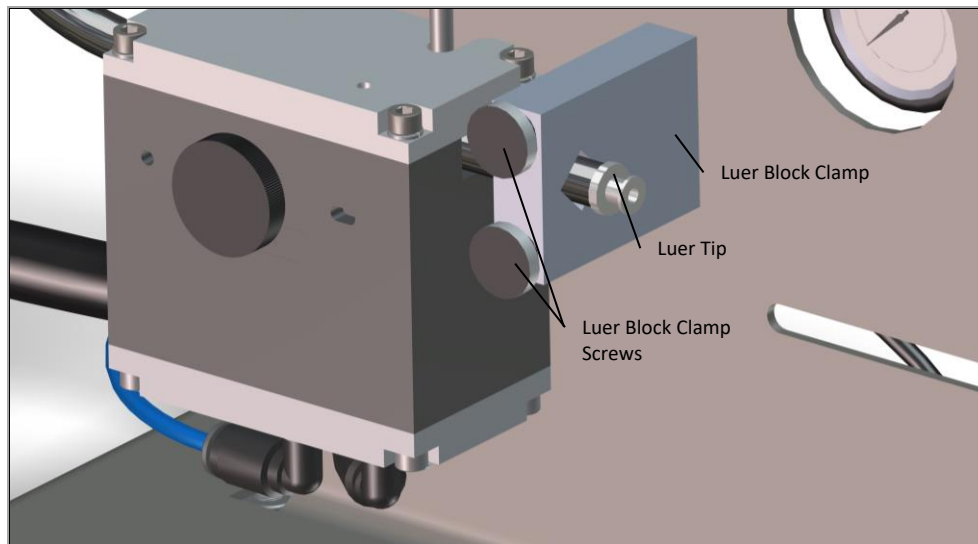
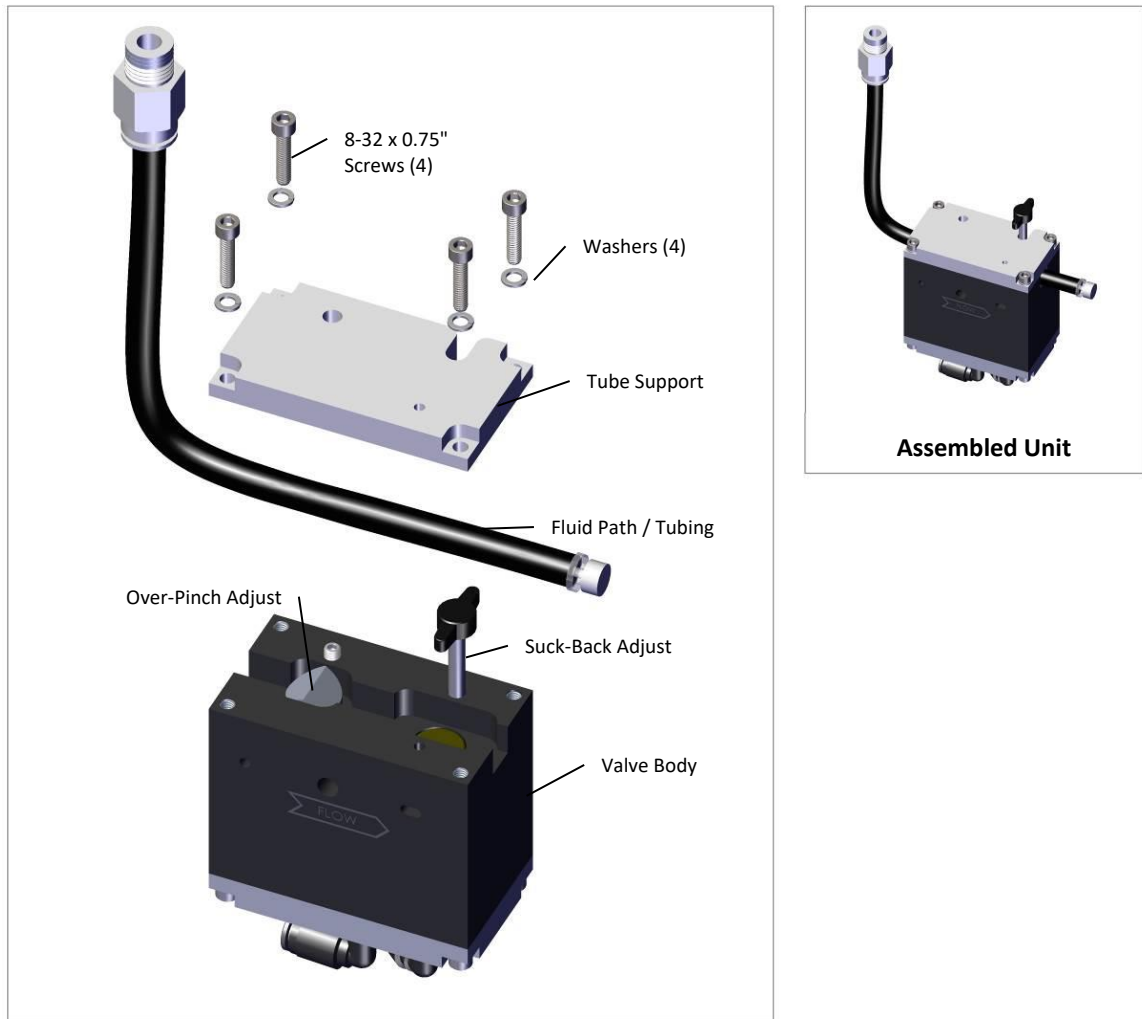

Figure 9. Fluid Path Installation

NOTE: Follow the same assembly and replacement for the following filling configurations:

T15225 TUBE ASSEMBLY, LUER FEMALE

Pressurizing the System

NOTE: Before operating the machine at the beginning of each run, check that all tubes, covers, guards, and safety devices are properly installed for operation.

The system is energized when a compressed air supply is connected to the System Pressure Inlet.

WARNING! Do not exceed 90 psi system pressure.

The following steps must be completed in order to safely pressurize the system. If these steps are not followed correctly, it is possible to create a situation that could result in a material spill through the Luer Tip.

1. Ensure that the Fluid Path is correctly installed in the Luer Support and the Tube Support.
2. Check that the Luer Clamp and the Tube Support are tightened down fully.
3. Ensure the Luer Tip Cap is installed and tightened onto the Luer Tip.
4. Disconnect the Material Reservoir Pressure Supply from the Material Reservoir Air Inlet.
5. Connect a Compressed Air Supply (max 90 psi) to the System Pressure Inlet.
6. Set the Air Regulator to 0 psi.
7. Connect the Material Reservoir Pressure Supply to the Material Reservoir Air Inlet.
8. Set the Air Regulator to 10 psi starting pressure.
9. Check for any material leaks occurring at the Luer Tip or at the Material Cartridge and depressurize the system if any leaks are present.

Depressurizing the System

1. Ensure the Luer Tip Cap is installed and tightened onto the Luer Tip.
2. Set the Air Regulator to 0 psi.
3. Disconnect the Material Reservoir Pressure Supply from the Material Reservoir Air Inlet.
4. Disconnect the Compressed Air Supply from the System Pressure Inlet.

Set the Fill Amount for the Syringe Size

For the required syringe size, use the scale to set the fill volume by adjusting the syringe fill stop to the desired location.

1. Disconnect the Compressed Air Supply from the System Pressure Inlet.
2. By hand, set the Syringe Plunger to the desired fill/mL volume.
3. Twist or slide the Syringe and extended Plunger on to the Nozzle/Needle/Luer Lock Tip of the Fluid Path.

4. Loosen the Syringe Fill Adjustment Lock by loosening the bottom two Allen Cap Screws (Figure 10).
5. Ensure the Syringe Fill Stop is “at rest”, and not extended.
6. Move the Syringe Fill Stop to the position where it immediately touches the extended Syringe Plunger.
7. From this position, gently slide the Syringe Fill Stop 5 scale lines *away* from the Syringe Plunger. The Syringe Fill Stop will retract to this position when each syringe reaches the desired fill volume.
8. Re-tighten the Syringe Fill Stop using Allen Cap Screws.

Figure 10. Model 1050 with Syringe Inserted

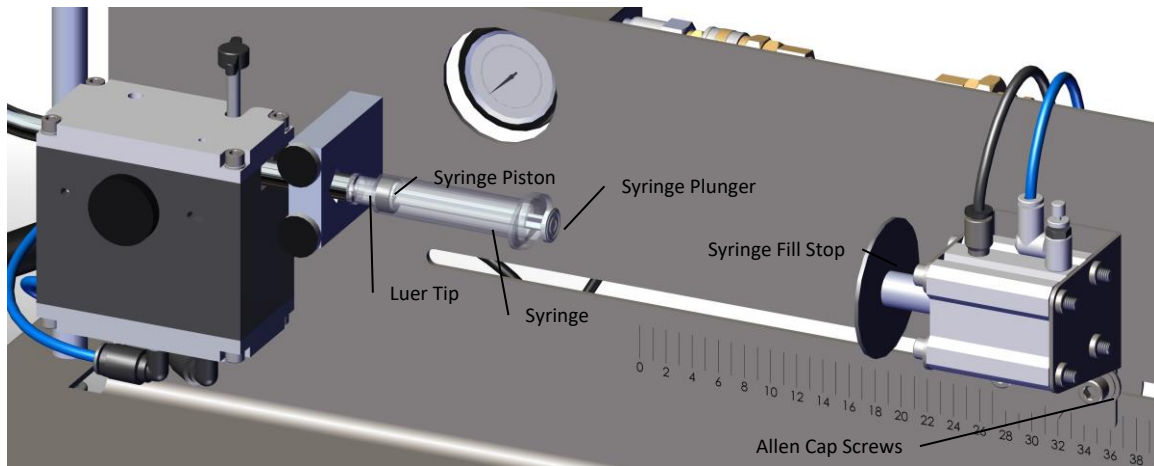

Priming the System

During initial setup and when changing material cartridge reservoirs, air must be purged from the disposable fluid path/fill tube to prevent accidental spills and introducing bubbles into syringes. Prime the system by running material through the fluid path until a constant, solid flow of material is achieved. Depending on material, reducing the pressure by 5-15 psi will make it easier to see the air being purged.

Prepare the Syringes

Before filling each syringe, ensure the syringe plunger is fully inserted to the tip of the syringe to remove most of the air from the empty syringe.

Fill the Syringe

1. Remove the Cap from the Luer Tip.
2. Load the required Syringe size by threading it onto the Luer Tip (Figure 10).
3. Make sure all hands and fingers are clear of the machine. Press and hold the Foot Switch to activate the filling cycle.
4. Release the Foot Switch when the Syringe Plunger touches the Syringe Fill Stop.

5. Remove the Syringe from the Luer Tip.
6. Cap the Syringe Tip and the Syringe End as needed.
7. Repeat above steps 2 through 6 for each additional syringe needed.

Model 830 Valve Adjustments

The 830 valve highlights a suck-back feature to prevent oozing and dripping between syringes. Depending on the type of fluids used, the suck-back feature will require adjustment. Batch-to-batch adjustment is recommended. If material drips, suck-back should be increased. If there are air bubbles in the syringe, decrease the amount of suck-back.

Adjusting Suck-Back Position (Front)

The Adjustment Screw is located on the top face of the valve. To increase suck-back, loosen the adjustment screw counter-clockwise. To decrease suck-back, tighten the adjustment screw clockwise. (Figure 11)

Figure 11. Suck-Back Adjustment Screw



Increase Suck-Back (Counter-Clockwise)



Decrease Suck-Back (Clockwise)

Cleaning and Maintenance

System Cleaning

Switching to a Different Material

The disposable fluid path in the Model 830 valve allows for quick and easy material changeover. To switch your system over from dispensing one material to dispensing a new material, simply replace the fluid path tube in the dispensing valve. You will also need to replace the material reservoir on the system. The new material can be placed in a new material reservoir or the existing reservoir can be cleaned and the material replaced.

Spare Parts and Accessories

Replacement Parts/Accessories

Part Number	Item
Air Lines & Regulators	
T16789	Air Supply Line
T18297	Material Regulator Replacement Kit
Reservoir Cartridge Kits	
T18306	20 oz Cartridge Assembly, HDPE
T18307	32 oz Cartridge Assembly, HDPE
Luer Block Parts	
T18294	V-Block Top with Mounting Thumb Screws
Model 830 Parts	
T18196	Model 830 Valve
T18304	Spare Hardware Kit Includes: Valve Mounting Screw, Suck Back Adjust Screw, Screws for the Tube Support
Tube Assemblies	
T15225	Tube Assembly, Luer Female
T18305	Tube Assembly, No Tip (For Use with Custom Tooling)
Misc.	
T18218	Bleed Wire with Pull Ring
T16603	Pneumatic Foot Switch
T18296	Stopper Assembly Replacement Kit
T40496	Luer-Lock Fitting, Female, Push-In (White)
T11978	Luer-Lock Fitting, Female, Push-In (Black)

Specifications

System Specifications

Materials of Construction—Wetted Parts

- Dispensing valve = No wetted parts
- Fluid tubing = light blocking, black, polyethylene
- Fluid tubing fittings = acetal
- Fluid cartridge reservoirs = HPDPE
- Fluid cartridge reservoir piston = HDPE

Operating Specifications

Recommended compressed air supply pressure to air filter/regulator = 60 psi min (4.1 bar)

Maximum pressure setting at air filter/regulator = 100 psi (6.9 bar)

Compatible material viscosity range: 1 – 60,000 cP

Reservoir Retainer/Tank Sizes

Cartridge retainers hold 20 and 32-oz (550 and 900-mL) reservoirs

1 gallon (3.8 L) jug and 5 gallon (15L) pail drop in reservoir options available: inquire with Tridak Customer Service

Air Regulator Pressure Gauges

Pressure gauge installed from factory = 0 to 100 psi (0 to 6.9 bar)

Dimensions

Dimensions (L x W x H) – 23.6 in x 12 in x 25 in (60 cm x 30.48 cm x 63.50 cm)

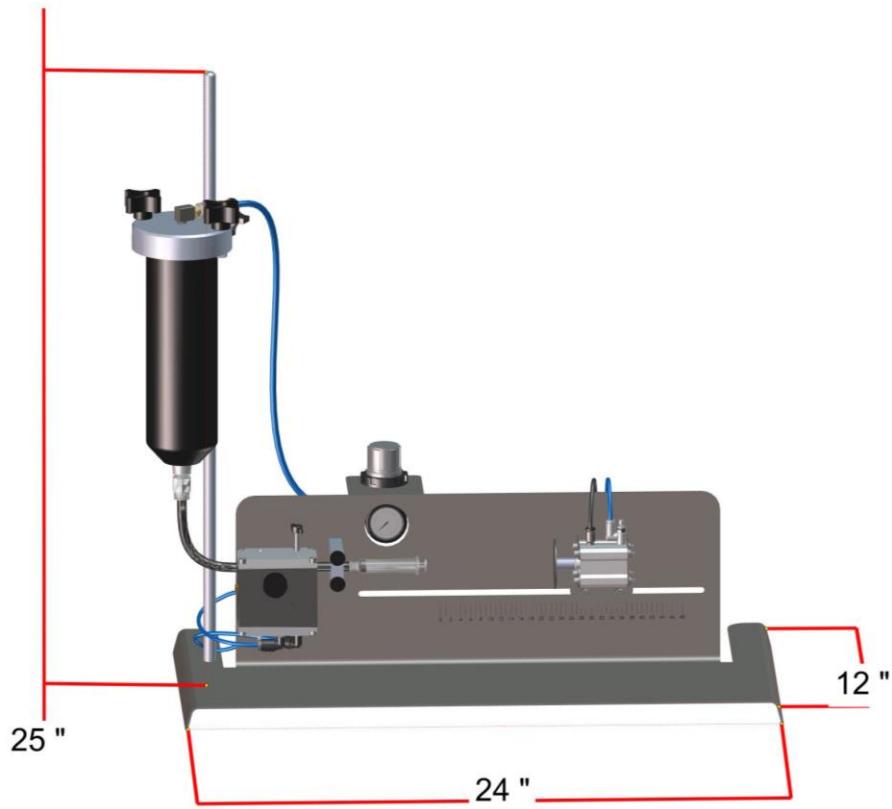

Figure 12. Model 1050 Syringe Loader Dimensions



Tridak LLC | 318 Industrial Lane, Torrington, CT 06790 USA | 860.626.6700 | info@tridak.com | www.tridak.com

© 2015-2022 Tridak LLC. All rights reserved. All trademarks in this guide, except where noted, are the property of, or used under license by Tridak LLC.

Please note that most filling and repackaging system applications are unique. Tridak does not warrant the fitness of the product for the intended application. Any warranty applicable to the product, its application and use is strictly limited to that contained in Tridak's standard Conditions of Sale. Tridak recommends that any intended application be evaluated and tested by the user to ensure that desired performance criteria are satisfied. Tridak is willing to assist users in their performance testing and evaluation. Data sheets are available for pressure pots upon request. TMAN005 12/21/2022