

# Tridak® Model 2400 User Guide

---

## High-Pressure Filling System

- Instructions for Safe Use
- Setup and Operation
- Maintenance
- Ordering Spare Parts and Accessories

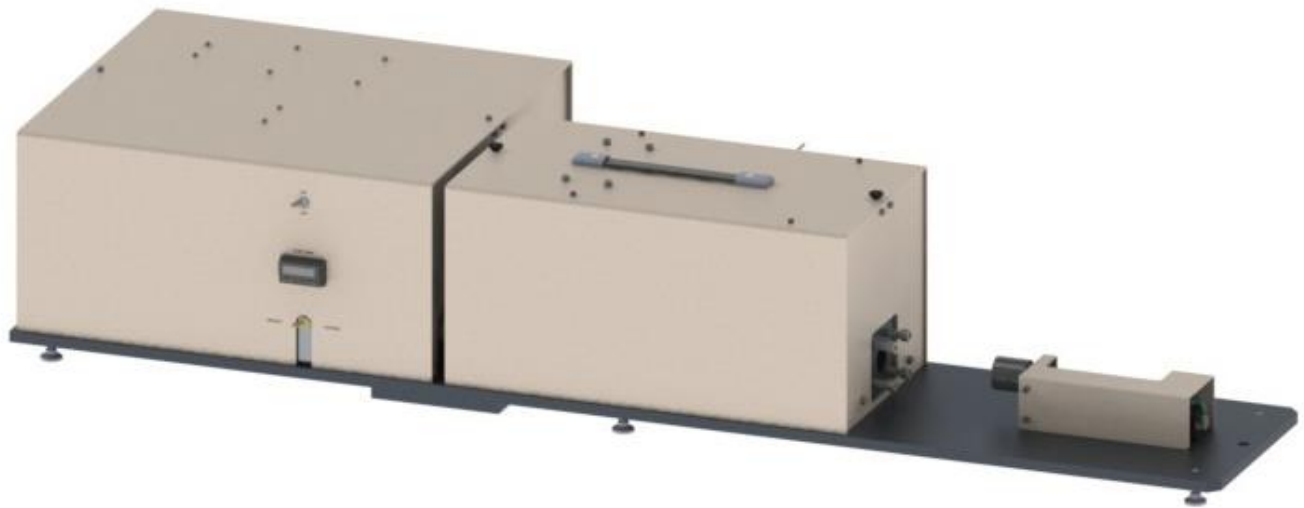

### **About Dymax**

#### **Light-curable materials as well as systems for light curing, fluid dispensing, and fluid packaging.**

Dymax manufactures a wide variety of light-curable oligomers, adhesives, and coatings as well as a complete line of manual and automatic fluid dispensing systems, light-curing systems, and fluid packaging equipment.

Our Tridak® brand fluid packaging systems are designed for use in numerous industries, including industrial, medical, dental, pharmaceutical, and food preparation. These filling systems provide significant productivity gains over manual and other more complicated and costly filling methods. The equipment is suited for all industry standard packaging as well as custom molded syringes and cartridges. We also possess the capability to fabricate nozzles and multi-port dispensing manifolds that perfectly match the packages being filled. Single- and dual-component materials can be packaged in seconds, one at a time, or in multiples for higher volume throughput. The equipment accommodates various mix ratios. High-pressure filling equipment is available for packaging highly filled materials in tiny syringes or compoules.

Please note that most filling system applications are unique. Dymax does not warrant the fitness of the product for the intended application. Any warranty applicable to the product, its application and use is strictly limited to that contained in the Dymax standard Conditions of Sale. Dymax recommends that any intended application be evaluated and tested by the user to insure that desired performance criteria are satisfied. Dymax is willing to assist users in their performance testing and evaluation.

# Contents

- Contents ..... 3**
- Introduction..... 4**
  - Introduction to the User Guide ..... 4
  - Where to Get Help ..... 4
- Safety..... 4**
  - General Safety Considerations ..... 4
  - Specific Safety Considerations..... 4
  - Personal Protective Equipment ..... 5
- Product Overview ..... 5**
  - Description of the Model 2400..... 5
  - Special Features and Benefits of the Model 2400 System ..... 5
  - Description of Main Components..... 6
- Assembly and Setup..... 8**
  - Unpacking and Inspecting Your Shipment..... 8
  - Utilities Required..... 8
  - Parts Included in the Model 2400 Filling System..... 9
- Operation ..... 9**
  - Operating the System..... 9
  - Replacing the Material Reservoir ..... 12
- Spare Parts and Accessories ..... 13**
  - Replacement Parts/Accessories ..... 13
- Specifications..... 13**
  - System Specifications ..... 13
  - Dimensions ..... 14
- Warranty ..... 14**
- Index..... 15**

# Introduction

## Introduction to the User Guide

This guide describes how to use the Tridak® Model 2400 High-Pressure Filling System (PN T10095). Sections in this guide describe how to assemble, use, and maintain the filling system safely and efficiently.

## Intended Audience

We prepared this user guide for experienced process engineers, technicians, and manufacturing personnel. If you are new to filling systems and do not understand the instructions, contact Application Engineering to answer your questions before using the equipment.

## Where to Get Help

Additional resources are available to ensure a trouble-free experience with our products:

- Detailed product information on [www.tridak.com](http://www.tridak.com)
- Customer Support and Application Engineering teams are available in the United States, Monday through Friday, from 8:00 a.m. to 5:30 p.m. Eastern Standard Time. You can also email us at [info@dymax.com](mailto:info@dymax.com). Please see the back cover of this user guide for worldwide contact information.

# Safety



**WARNING!** *If you use this filling system without first reading and understanding the information in this user guide, injury can result. To reduce the risk of injury, read and ensure you understand the information in this user guide before assembling and operating a Tridak filling system.*

## General Safety Considerations

All users of Tridak filling equipment should read and understand this user guide before assembling and using the equipment.

## Specific Safety Considerations

### Using Safe Operating Pressures

Pressurizing the components in the dispensing system beyond the maximum recommended pressure can result in the rupturing of components and serious personal injury. To minimize the risk of rupturing components and injury, do not exceed the maximum operating pressure of the components in your filling system. (See system specifications on page 13)

## Preventing Injection Injury

Discharging fluids or compressed air with a dispensing tip against your skin can cause very serious injection injury. To minimize the risk of injection injury, do not place the dispensing tip in contact with your skin.

## Personal Protective Equipment

Operators are recommended to wear any personal protective equipment specified by their company's safety policy for the materials used during filling. Personal protective equipment should be in place and used at all times before pressurizing the system and when handling any potentially hazardous materials.

# Product Overview

## Description of the Model 2400

The Model 2400 High-Pressure Filling System accurately fills packages with extremely high-viscosity materials such as dental composites and restoratives. Due to their high content of “filler”, these materials can be hard to dispense and can clog typical filling machines. The high-pressure filler uses a convection oven to lower the viscosity of the material and then routes materials through the system and into the containers using high pressure.

## Special Features and Benefits of the Model 2400 System

- Dispenses extremely high-viscosity, materials with high “filler” content
- Includes a forced convection oven to lower material viscosity
- Fills single or multiple syringes and up to 5 compoules simultaneously
- Solid-state sensing system controls the amount of fill
- Dimensions (W x H x L): 18 in x 11.125 in x 56.75 in [45.72 cm x 28.26 cm x 144.15 cm]

## Description of Main Components

The main components in the Model 2400 filling system include:

**Figure 1. Main System Components (Front)**

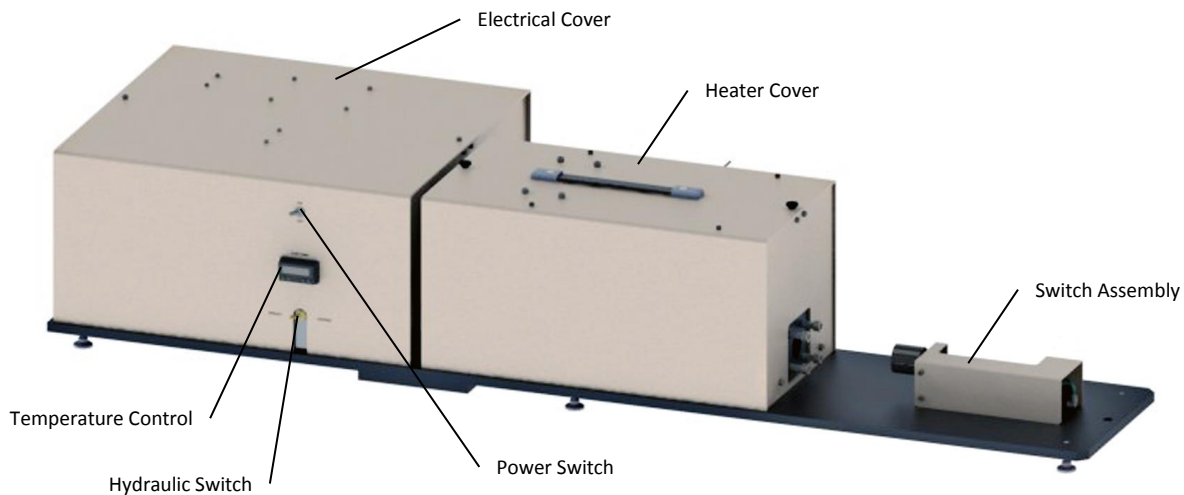

**Figure 2. Main System Components (Rear)**

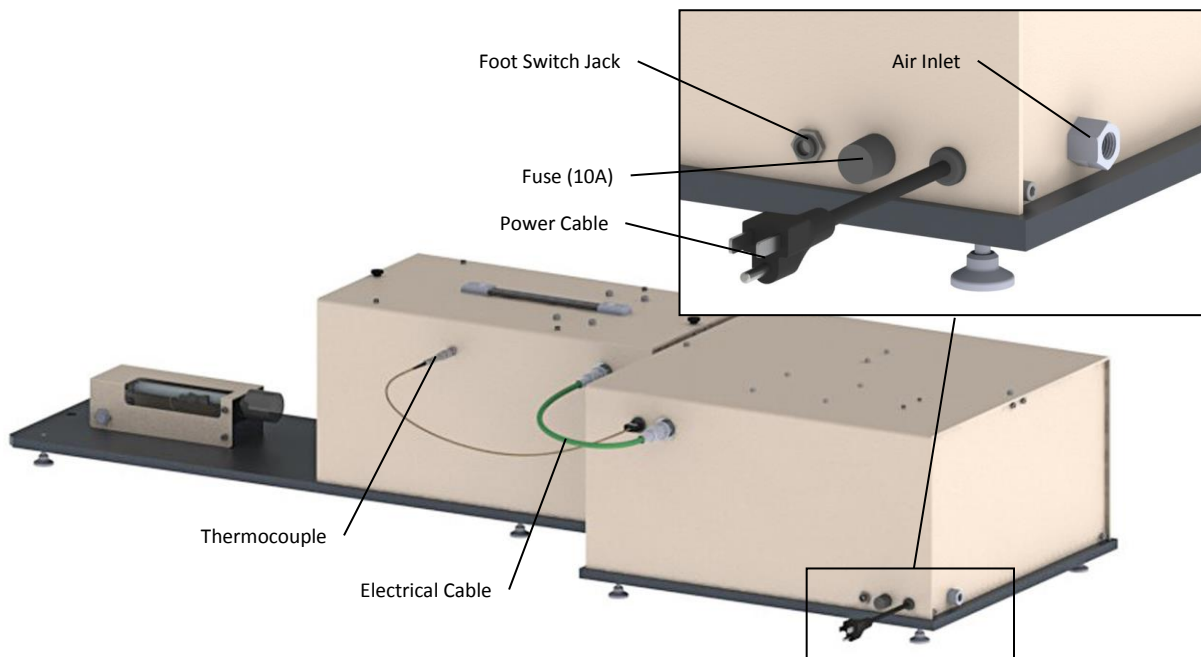

Figure 3. Electrical Cover

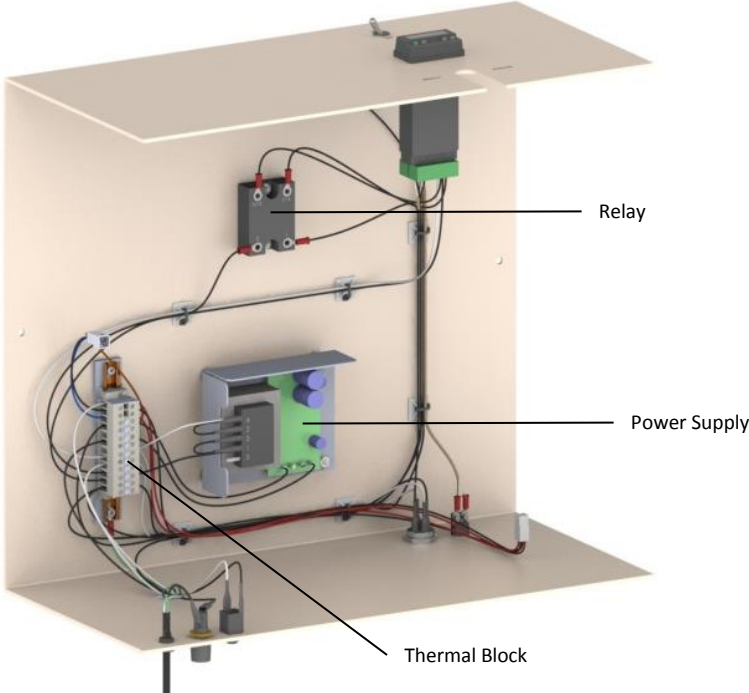
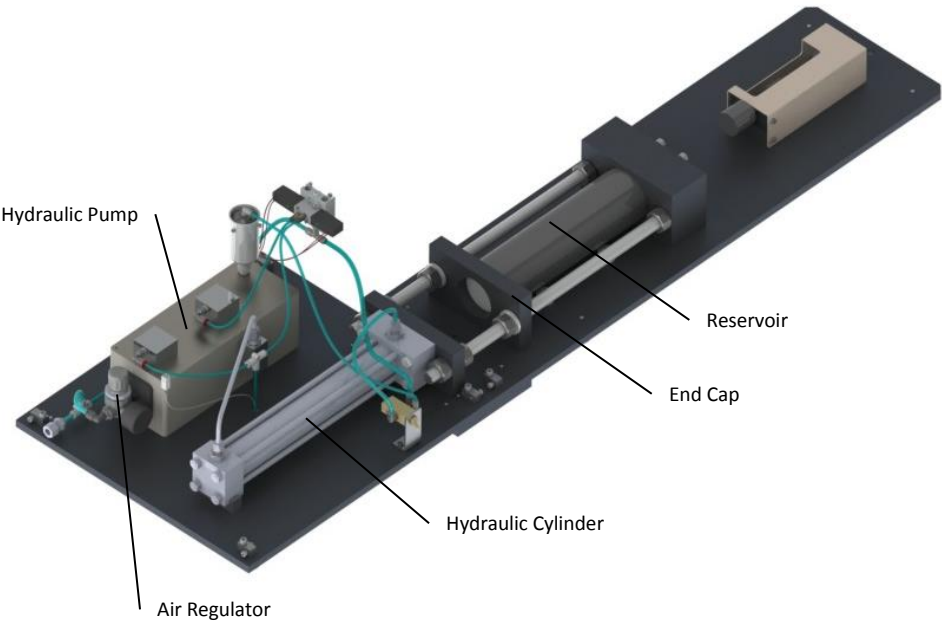
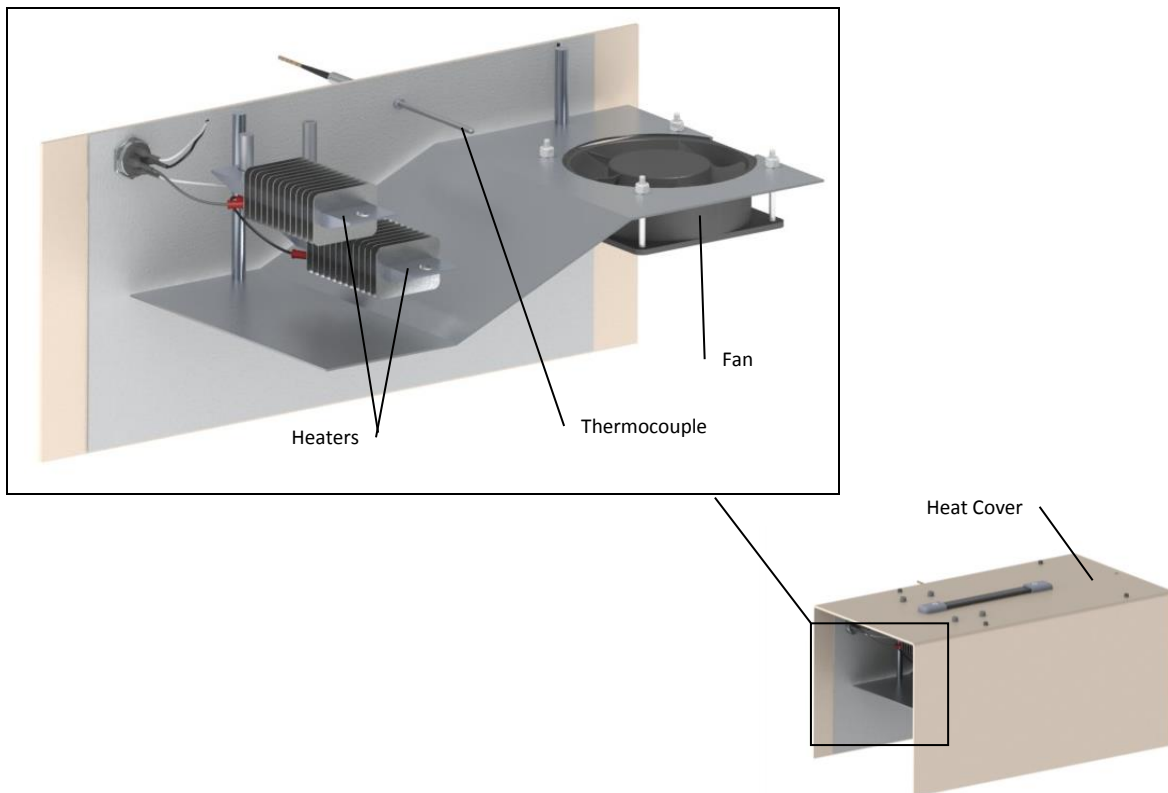

Figure 4. Main Interior Components



**Figure 5. Heat Cover**

## Assembly and Setup

### Unpacking and Inspecting Your Shipment

Your filling system arrived in one or two boxes. Inspect the boxes for damage and notify the shipper of box damage immediately.

Open each box and check for equipment damage. If parts are damaged, notify the shipper and submit a claim for the damaged parts. Contact Dymax so that new parts can be shipped to you immediately.

Check that the parts included in your order match those listed below. If parts are missing, contact your local Dymax representative or Dymax Customer Support to resolve the problem.

### Utilities Required

Power: 110 VAC, 50/60 Hz

Air: Clean, dry, non-lubricated air operating pressure of 60-90 psi [4-6 bar]



## Parts Included in the Model 2400 Filling System

- Model 2400 filling system
- Model 2400 filling system user manual
- 2 Reservoirs with caps
- Foot switch

# Operation

## Operating the System

1. Remove the Thumb Screws (Figure 6, A) and lift off the Heater Cover (Figure 6, B).
2. Position the preheated reservoir into the Reservoir Guides (Figure 6, E).
3. Push the Reservoir (Figure 6, D) into the Front Cap (Figure 6, I).
4. Slide the End Cap (Figure 6, G) forward until it rests against the Reservoir.
5. Secure the End Cap into position by tightening the Cylinder Nuts (Figure 6, G) until the Cup Washers are flat.
6. Replace the Heater Cover (Figure 6, B) and Thumb Screws (Figure 6, A).
7. Insure that the Hydraulic Switch (Figure 6, F) in is the dispense position.
8. Place a syringe onto the Nozzle to be filled (Figure 7).
9. Depress the Footswitch.
10. After the syringe is filled, the system will automatically stop and wait to be to be reloaded.
11. Continue these instructions until the Reservoir is emptied.

**Figure 6. Loading the System, Exploded View**

Figure 7. Syringe Filling Process



## Replacing the Material Reservoir

Follow the instructions below to replace the material reservoir with a new preheated reservoir.

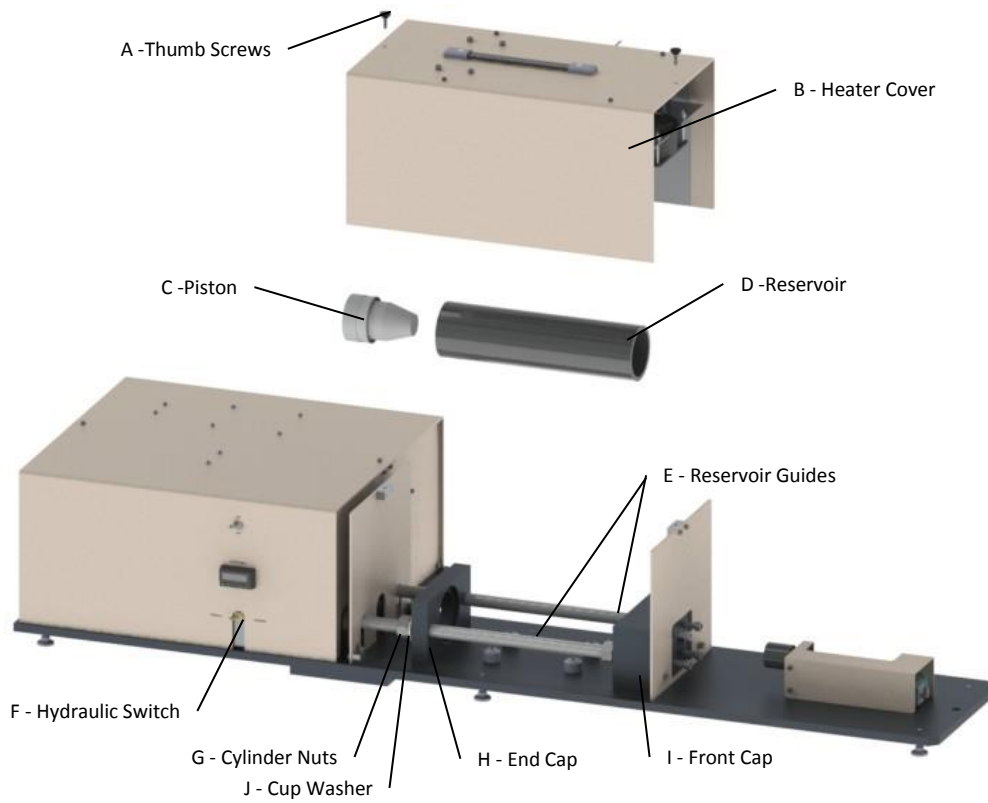
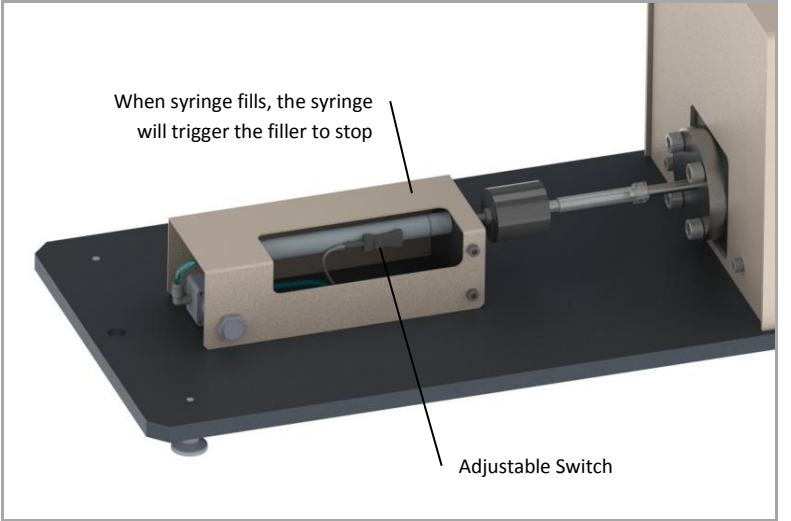
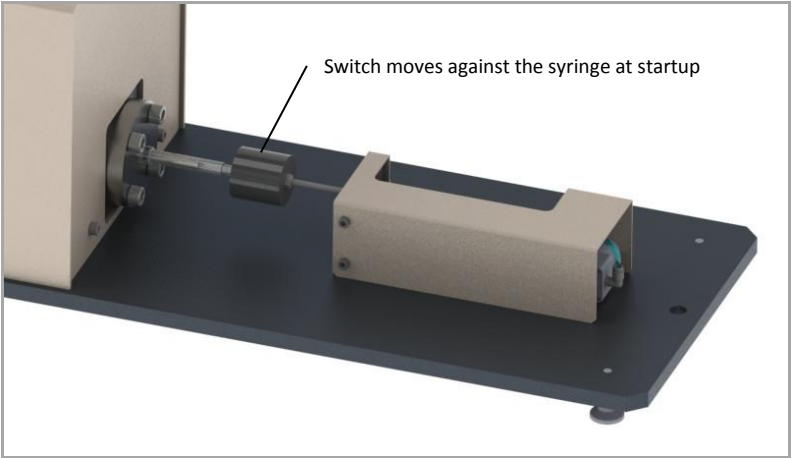
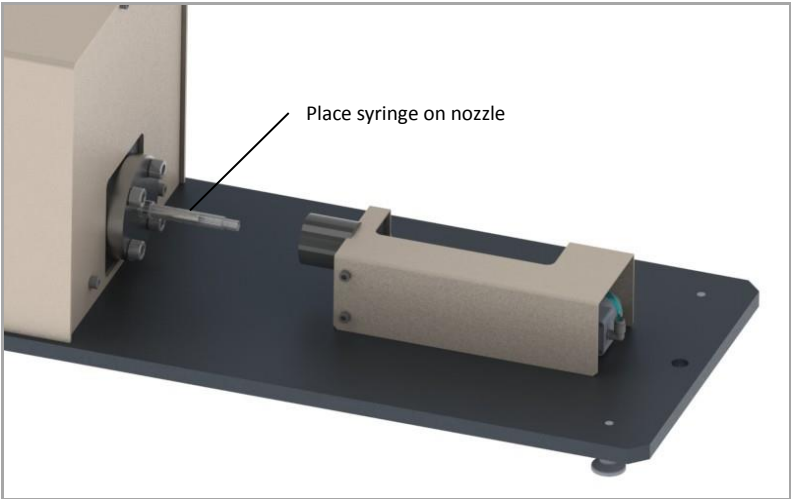
- Change the Hydraulic Switch to the retract position so that the piston retracts to the home position.
- Remove the Thumb Screws and lift off the Heater Cover.
- Back off the Cylinder Nuts.
- Remove the Reservoir by pulling it backwards and up.
- Position the preheated reservoir into the Reservoir Guides.
- Push the Reservoir into the Front Cap.
- Slide the End Cap forward until it rests against the Reservoir.
- Secure the End Cap into position by tightening the Cylinder Nuts until the Cup Washers are flat.
- Replace the Heater Cover and Thumb Screws.
- Change the Hydraulic Switch to the dispense position.

**Figure 8. Replacing the Material Reservoir**

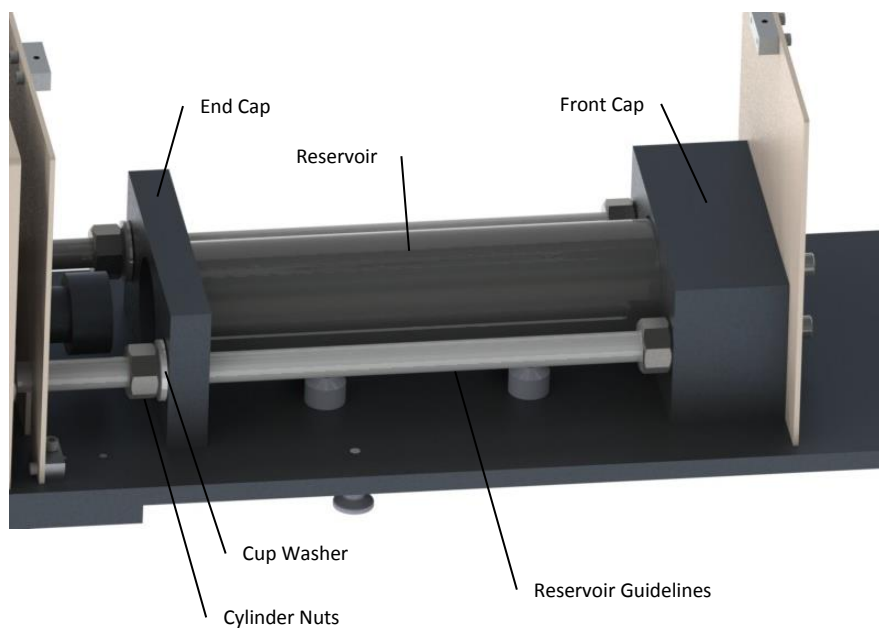

# Spare Parts and Accessories

## Replacement Parts/Accessories

Item	Part Number
Single Nozzle Tooling for CompuLe or Syringe	T15670
Amalgon Cylinder, Black	T12579
Amalgon Cylinder Cap, Black	T13686
Hydraulic Pump	T13915
Scraper Piston, 2 Pieces	T15458

# Specifications

## System Specifications

### Materials of Construction—Wetted Parts (Figure 9)

- Piston: Delrin
- Cylinder: Black Amalgon
- Front Cap: Black Hard Coat TFE Impregnated 6061-T6 Aluminum
- Nozzle (Suggested): Stainless Steel with Armaloy Plating

### Operating Specifications

Recommended compressed air supply pressure to air filter/regulator = 80 to 100 psi (5.5 to 6.9 bar)

Maximum pressure setting at air filter/regulator = 80 psi (5.5 bar)

**Figure 9. Wetted Parts**

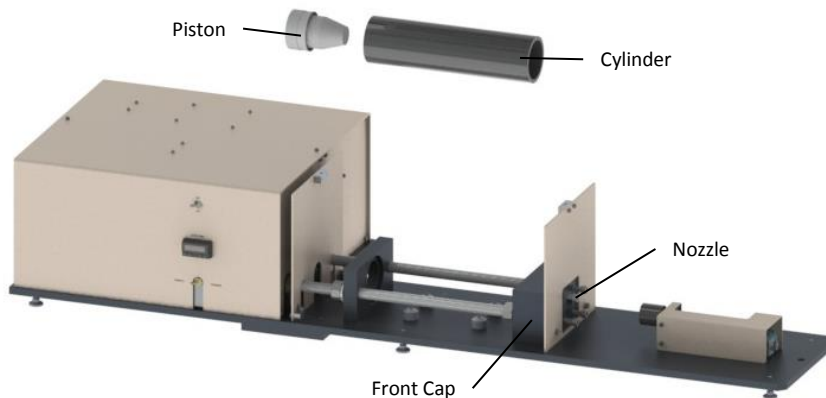

## Dimensions

System Dimensions (W x H x L): 18 in x 11.125 in x 56.75 in [45.72 cm x 28.26 cm x 144.15 cm]

**Figure 10. Model 2400 Dimensional Diagram**

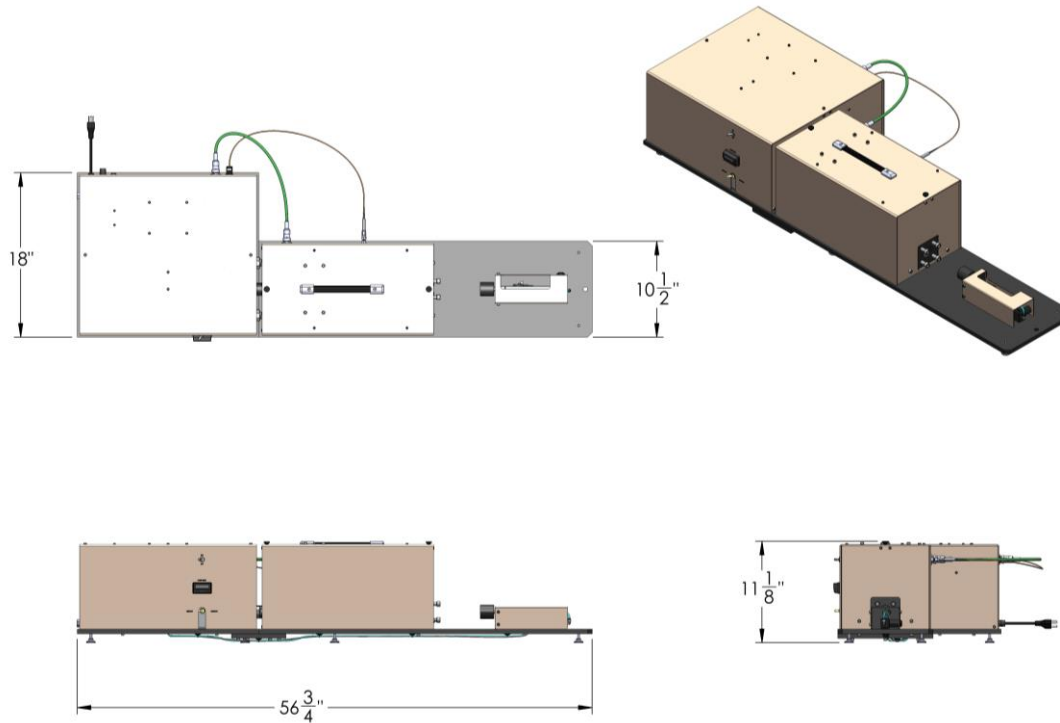

## Warranty

From date of purchase, Dymax offers a one-year warranty against defects in material and workmanship on all system components with proof of purchase and purchase date. Unauthorized repair, modification, or improper use of equipment may void your warranty benefits. The use of aftermarket replacement parts not supplied or approved by Dymax, will void any effective warranties and may result in damage to the equipment.

**IMPORTANT NOTE:** DYMAX RESERVES THE RIGHT TO INVALIDATE ANY WARRANTIES, EXPRESSED OR IMPLIED, DUE TO ANY REPAIRS PERFORMED OR ATTEMPTED ON DYMAX EQUIPMENT WITHOUT WRITTEN AUTHORIZATION FROM DYMAX. THOSE CORRECTIVE ACTIONS LISTED ABOVE ARE LIMITED TO THIS AUTHORIZATION.

# Index

- Assembly
  - Utilities, 8
- Assembly and Setup, 8
- Compressed Air Requirements, 8
- Description of System Components, 6
- Dimensions, 14
- Help, 4
- Operation, 9
- Optional Equipment, 13
- Parts Included, 9
- Product Overview, 5
- Replacing the Material Reservoir, 12
- Safety, 4
  - Personal Protective Equipment, 5
  - Preventing Injection Injury, 5
  - Using Safe Operating Pressures, 4
- Spare Parts and Accessories, 13
- Specifications, 13
- Support, 4
- System Features, 5
- Unpacking, 8
- Utilities, 8
- Warranty, 14



© 2012-2016 Dymax Corporation. All rights reserved. All trademarks in this guide, except where noted, are the property of, or used under license by Dymax Corporation, U.S.A.

Please note that most filling and repackaging system applications are unique. Dymax does not warrant the fitness of the product for the intended application. Any warranty applicable to the product, its application and use is strictly limited to that contained in Dymax's standard Conditions of Sale. Dymax recommends that any intended application be evaluated and tested by the user to insure that desired performance criteria are satisfied. Dymax is willing to assist users in their performance testing and evaluation. Data sheets are available for pressure pots upon request.

T17238 MAN031 9/21/2012

**Dymax Corporation**

+1.860.482.1010 | info@dymax.com | [www.dymax.com](http://www.dymax.com)

**Dymax Europe GmbH**

+49 611.962.7900 | info\_de@dymax.com | [www.dymax.de](http://www.dymax.de)

**Dymax Engineering Adhesives Ireland Ltd.**

+353 21.237.3016 | info\_ie@dymax.com | [www.dymax.ie](http://www.dymax.ie)

**Dymax Oligomers & Coatings**

+1.860.626.7006 | info\_oc@dymax.com | [www.dymax-oc.com](http://www.dymax-oc.com)

**Dymax UV Adhesives & Equipment (Shanghai) Co. Ltd.**

+86.21.37285759 | dymaxasia@dymax.com | [www.dymax.com.cn](http://www.dymax.com.cn)

**Dymax UV Adhesives & Equipment (Shenzhen) Co. Ltd.**

+86.755.83485759 | dymaxasia@dymax.com | [www.dymax.com.cn](http://www.dymax.com.cn)

**Dymax Asia (H.K.) Limited**

+852.2460.7038 | dymaxasia@dymax.com | [www.dymax.com.cn](http://www.dymax.com.cn)

**Dymax Asia Pacific Pte. Ltd.**

+65.6752.2887 | info\_ap@dymax.com | [www.dymax-ap.com](http://www.dymax-ap.com)

**Dymax Korea LLC**

+82.2.784.3434 | info\_kr@dymax.com | [www.dymax.com/kr](http://www.dymax.com/kr)