

# Tridak® Model 1200 User Guide

## Dual-Component Syringe Filling System with Disposable Fluid Path Technology

- Instructions for Safe Use
- Setup and Operation
- Maintenance
- Ordering Spare Parts and Accessories

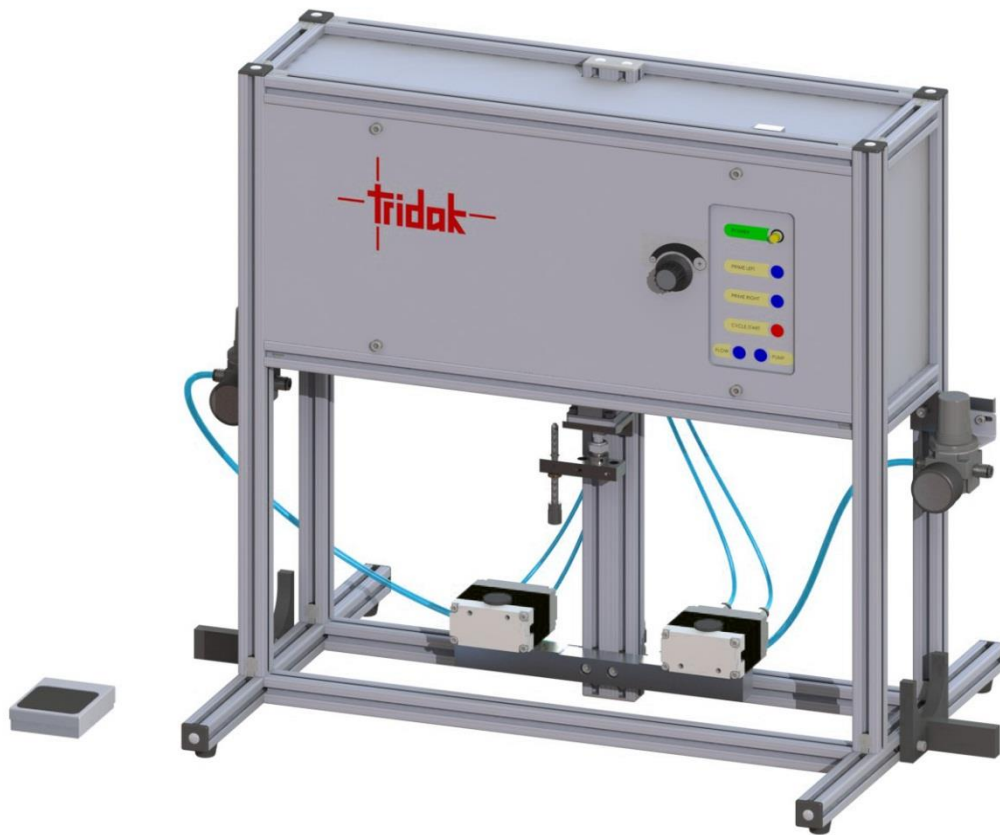

### **About Dymax**

#### **Light-curable materials as well as systems for light curing, fluid dispensing, and fluid packaging.**

Dymax manufactures a wide variety of light-curable oligomers, adhesives, and coatings as well as a complete line of manual and automatic fluid dispensing systems, light-curing systems, and fluid packaging equipment.

Our Tridak® brand fluid packaging systems are designed for use in numerous industries, including industrial, medical, dental, pharmaceutical, and food preparation. These filling systems provide significant productivity gains over manual and other more complicated and costly filling methods. The equipment is suited for all industry standard packaging as well as custom molded syringes and cartridges. We also possess the capability to fabricate nozzles and multi-port dispensing manifolds that perfectly match the packages being filled. Single- and dual-component materials can be packaged in seconds, one at a time, or in multiples for higher volume throughput. The equipment accommodates various mix ratios. High-pressure filling equipment is available for packaging highly filled materials in tiny syringes or compoules.

Please note that most filling system applications are unique. Dymax does not warrant the fitness of the product for the intended application. Any warranty applicable to the product, its application and use is strictly limited to that contained in the Dymax standard Conditions of Sale. Dymax recommends that any intended application be evaluated and tested by the user to insure that desired performance criteria are satisfied. Dymax is willing to assist users in their performance testing and evaluation.

# Contents

<b>Introduction .....</b>	<b>4</b>
Introduction to the User Guide .....	4
Where to Get Help .....	4
<b>Safety .....</b>	<b>4</b>
General Safety Considerations .....	4
Specific Safety Considerations.....	5
Personal Protective Equipment.....	5
<b>Product Overview .....</b>	<b>5</b>
Description of the Model 1200 Syringe Filling System .....	5
Special Features and Benefits of the Model 1200 Syringe Filler .....	5
Description of Main Components.....	6
<b>Assembly and Setup.....</b>	<b>6</b>
Unpacking and Inspecting Your Shipment.....	6
Utilities Required .....	7
Parts Included in Model1200 Syringe Filling System .....	7
<b>Preparing the System for Use .....</b>	<b>7</b>
Cartridge Retainer Preparation .....	7
System Interconnect.....	8
Installing Fill Tubing .....	8
<b>Priming the System .....</b>	<b>9</b>
<b>Operating the System .....</b>	<b>11</b>
Entering Mode of Operation .....	11
Filling a Syringe.....	11
Speed Control Adjustments.....	11
<b>Reloading System Material.....</b>	<b>11</b>
<b>Replacing the Fill Tubing .....</b>	<b>12</b>
<b>Spare Parts and Accessories .....</b>	<b>12</b>
<b>Specifications.....</b>	<b>13</b>
System Specifications .....	13
<b>Warranty .....</b>	<b>14</b>
<b>Index .....</b>	<b>15</b>

# Introduction

## Introduction to the User Guide

This guide describes how to use the Tridak® Model 1200 Syringe Filling System. Sections in this guide describe how to assemble, use, and maintain the filling system safely and efficiently.

## Other Documentation Included

In addition to this guide, the following documentation is included with your filling system:

- User guide for the Model 828 dispensing valve – MAN034
- OEM user guide for the air regulators

## Intended Audience

This user guide was prepared for experienced process engineers, technicians, and manufacturing personnel. If you are new to filling systems and do not understand the instructions, contact Dymax Application Engineering to answer your questions before using the equipment.

## Where to Get Help

Additional resources are available to ensure a trouble-free experience with our products:

- Detailed product information on [www.tridak.com](http://www.tridak.com)
- Customer Support and Application Engineering teams are available in the United States, Monday through Friday, from 8:00 a.m. to 5:30 p.m. Eastern Standard Time. You can also email us at [info@dymax.com](mailto:info@dymax.com). Please see the back cover of this user guide for worldwide contact information.

# Safety



**WARNING!** *If you use this filling system without first reading and understanding the information in this user guide, injury can result. To reduce the risk of injury, read and ensure you understand the information in this user guide before assembling and operating a Tridak filling system.*

## General Safety Considerations

All users of Tridak filling equipment should read and understand this user guide before assembling and using the equipment.

## Specific Safety Considerations

### Using Safe Operating Pressures

Pressurizing the components in the dispensing system beyond the maximum recommended pressure can result in the rupturing of components and serious personal injury. To minimize the risk of rupturing components and injury, do not exceed the maximum operating pressure of the components in your filling system (See system specifications on page 13).

### Preventing Injection Injury

Discharging fluids or compressed air with a dispensing tip against your skin can cause very serious injection injury. To minimize the risk of injection injury, do not place the dispensing tip in contact with your skin.

### Personal Protective Equipment

Operators are recommended to wear any personal protective equipment specified by their company's safety policy for the materials used during filling. Personal protective equipment should be in place and used at all times before pressurizing the system and when handling any potentially hazardous materials.

## Product Overview

### Description of the Model 1200 Syringe Filling System

*Note: These machines are customized to accept specific syringes with plungers fully inserted.*

The Tridak® Model 1200 Syringe Filling Machine is designed to fill dual-component syringe cartridges simultaneously. The machine is set up to accept two different materials from pressurized reservoirs, making it an ideal filling station for materials requiring two-component mixing, such as epoxies or composite resins. The system can also be configured to fill small, single-component syringes.

The filling process requires an operator to load the empty syringes onto the fill nozzles and then activate the filling system using the foot switch. The internal PC of the system controls all functions of this system. The adjustable stroke controls the full-stroke volume.

### Special Features and Benefits of the Model 1200 Syringe Filler

The Model 1200 syringe filling system is engineered for precise performance and long service life. Key features include:

- Utilizes disposable fluid path valve technology which eliminates cross-contamination and minimizes clean-up and downtime during product changeover
- Fills two-component syringes simultaneously with the same or separate materials
- Fill times from 2-6 seconds
- Adjustable fill level
- Two modes of operation (Pump Mode & Flow Mode) for materials with various viscosities
- Nozzle-end filling process with pre-inserted plunger minimizes air entrapment

## Description of Main Components

Figure 1. Main Components of a Model 1200 Syringe Filling System

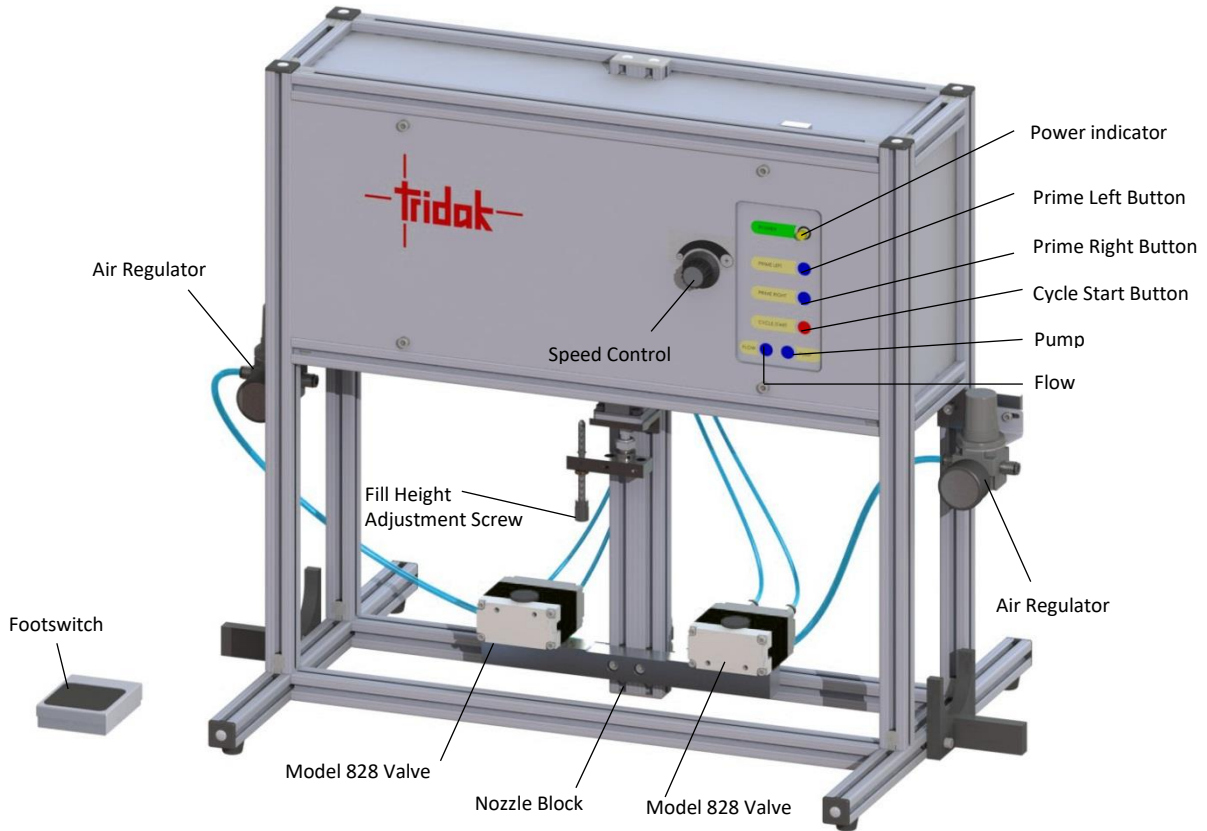

## Assembly and Setup

### Unpacking and Inspecting Your Shipment

When your syringe filling system arrives, inspect the boxes for damage and notify the shipper of box damage immediately.

Open each box and check for equipment damage. If parts are damaged, notify the shipper and submit a claim for the damaged parts. Contact Dymax so that new parts can be shipped to you immediately.

The parts listed below will be included in your shipment. If parts are missing, contact your local Dymax representative or Dymax Customer Support to resolve the problem.

## Utilities Required

Air: 60-80 psi (0.41-0.55 MPa), 50 micron filtered, non-lubricated; dry air is required

Electric: 120 VAC, 50/60 Hz

## Parts Included in Model 1200 Syringe Filling System

- Model 1200 Syringe Filling System (T17563)
- Air Line Kit (T16789)
- Fluid Line Kit, 3/8" OD Black Polyethylene Tubing (T16787)
- Footswitch (T14999)
- Power Cord, 110 VAC, 7 Ft. (T17021)
- Printed User Manual (T17566)

# Preparing the System for Use



### **WARNINGS & PRECAUTIONS!**

*The supply air MUST be connected before connecting air to reservoir! Disconnect the air to reservoirs BEFORE supply air is disconnected! The Model 828 dispensing valve used in this system is normally open. Don't start without a syringe in place!*

## Cartridge Retainer Preparation

1. Install Cartridge End Fitting onto a Cartridge Retainer.
2. Place a filled Cartridge into the Cartridge Retainer.
3. Install and securely tighten the Cartridge Retainer Cover Assembly onto the Cartridge Retainer.

**Figure 2.20 oz. Cartridge Retainer**

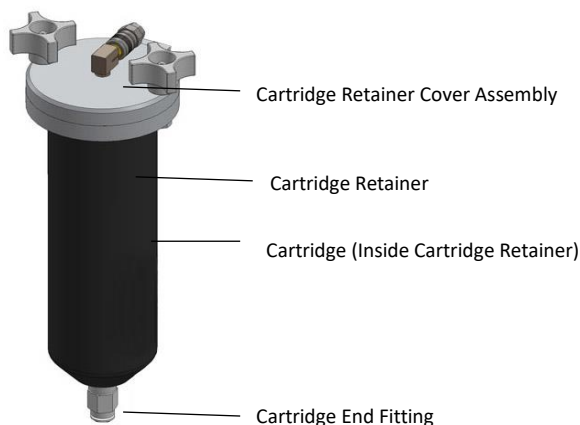

## System Interconnect

1. Plug the Power Plug into the Power Connection (Figure 3) on the machine's back panel.
2. Connect the Footswitch to the Footswitch Jack (Figure 3) on the machine's back panel.
3. Connect the supply air to the 1/4 NPT Air Inlet on the rear of the unit (Figure 3). Set the pressure to 65 psi (0.44 MPa).

**Figure 3. Connections (Rear Panel)**

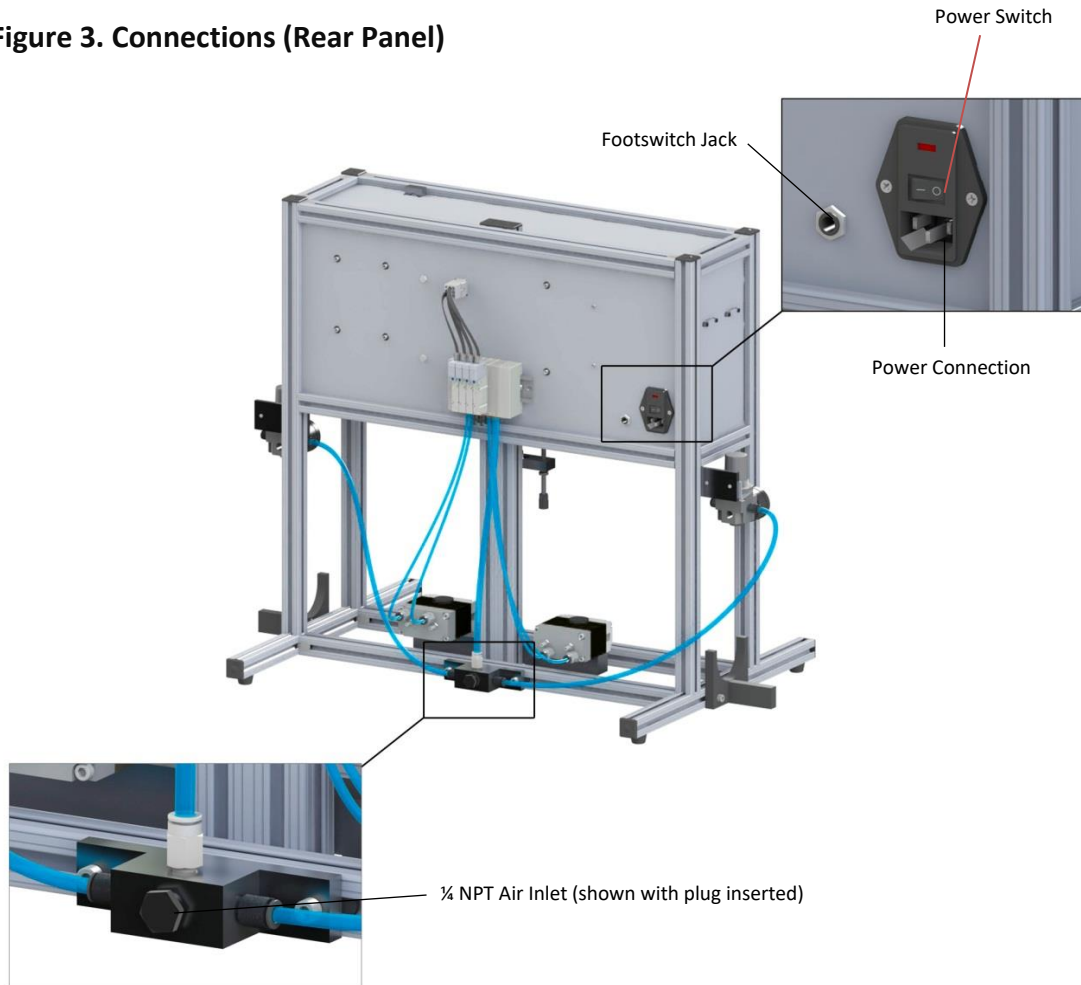

## Installing Fill Tubing

### Connecting Fill Tubing to the Dispensing Valves

1. Remove the Tubing Retainer Plate from the dispensing valve.
2. Cut one piece of 3/8" OD x 1/16" tubing to a length of 6 inches.

*Note: 3/8"OD black polyethylene tubing is included with shipment. Bulk tubing of other material compositions is available from Tridak.*

3. Position the fill tubing as shown (Figure 4), and press firmly into the Nozzle Block Fitting (Figure 4, A).



*Note: Be sure the Fill Tubing is bottomed out when installing into the Nozzle Block.*

4. Reinstall the Tubing Retainer Plate (Figure 4, B) onto the dispensing valve, and carefully tighten the four screws evenly.
5. Repeat steps 1-4 for the second dispensing valve.

*Note: Make sure the material cartridge on the right containing “Part A” is attached to the tubing coming from the right-side valve. Make sure the material cartridge on the left containing the “Part B” is attached to the tubing coming from the left-side valve.*

## Installing Cartridge Retainers to Fill Tubing

1. Connect the Cartridge Retainer (Figure 4, G) to the Fill Tubing (Figure 4, D) by sliding the Cartridge End Fitting (Figure 4, F) onto the Fill Tubing (Figure 4, D).
2. Place the Cartridge Retainer (Figure 4, G) into the Cartridge Retainer Cradle (Figure 4, H).

*Note: To minimize air pockets when reloading, push down on the cartridge piston until material is at the cartridge fitting end and then install the cartridge retainer.*

### Figure 4. Connecting Fill Tubing to the Dispensing Valves

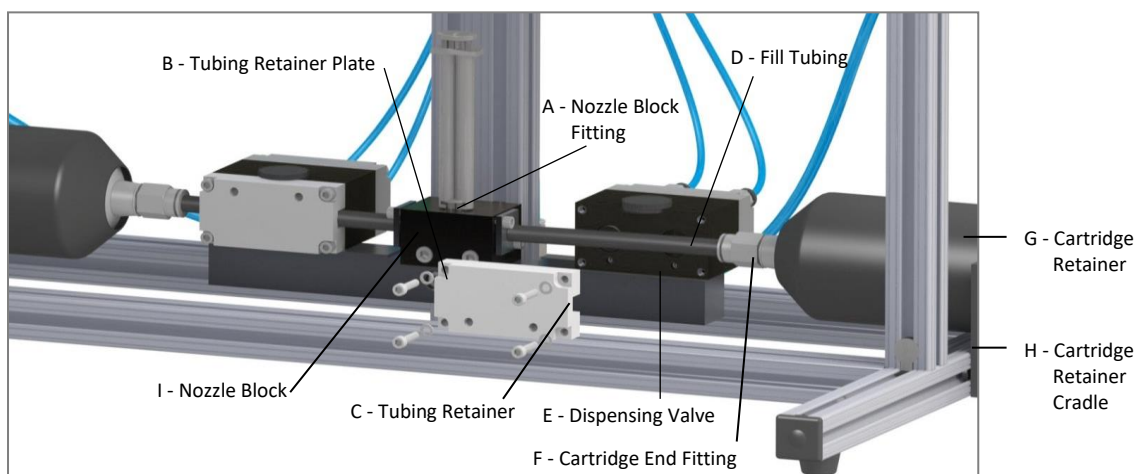

## Priming the System

1. Toggle the Power Switch located above the Power Connection (Figure 3) to turn the system on. The light to the right of the Power Button will turn green.
2. Remove the plunger from a syringe and install the nozzle end of the syringe into the Nozzle Block (Figure 4).
3. Press the Prime Left Button (Figure 5) to start filling the syringe. Continue to push the Prime Left Button until all the air in the system has been expelled.

4. Press the Prime Right Button (Figure 5) to start filling the syringe. Continue to push the Prime Right Button until all the air in the system has been expelled.
5. The unit is now primed and can be used to fill a syringe, complete with plunger.

**Figure 5. Control Panel**

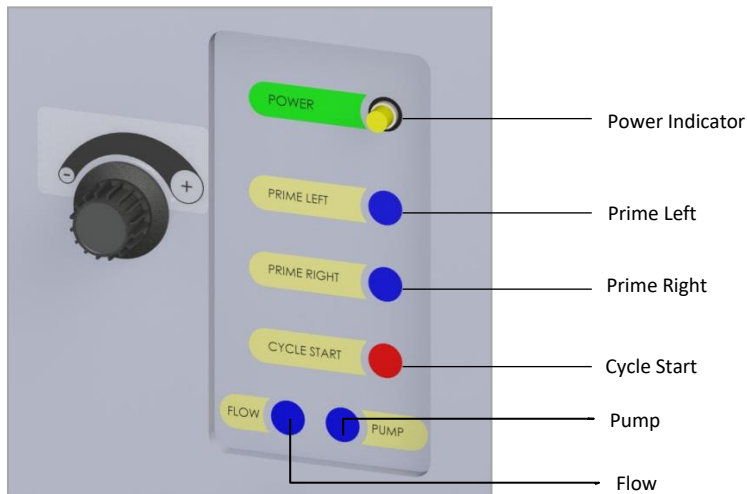

### Setting the Fill Height

To adjust the fill height, loosen the Jam Nut and turn the Fill Height Adjustment Screw accordingly (Figure 6).

**Figure 6. Fill Adjustment Controls**

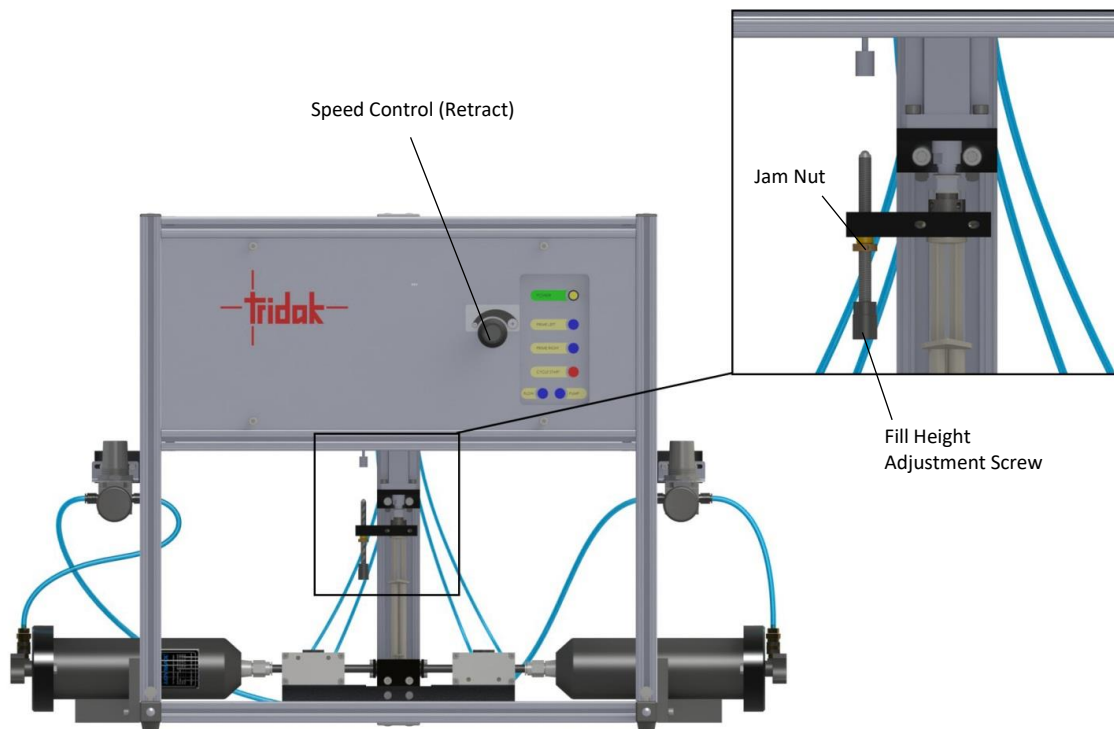

# Operating the System

## Entering Mode of Operation

The unit has two modes of operation, Pump Mode and Flow Mode. Pressing one of these buttons (Figure 5) while the unit is idle will enter the system into the respective mode.

**Pump Mode** allows the valves to operate continuously throughout the entire filling sequence and is recommended for higher viscosity materials to aid in filling.

**Flow Mode** allows the valves to operate only a few times during the filling process and is recommended for lower viscosity materials.

*Note: Some experimentation will need to be done to determine the best mode of operation for the material you are using.*

## Filling a Syringe

Once the system is set up, purged, the fill height has been adjusted, and the mode has been selected, it is ready to fill a syringe. Place an empty syringe with a plunger inserted onto the Nozzle Block. Simply press the Footswitch or the Cycle Start Button (Figure 5). The unit will run until the Height Adjustment reaches the end of its stroke and the stop. When the unit has stopped, the syringe can be removed and replaced.

## Speed Control Adjustments

The Model 1200 allows for complete and quick filling of syringes by controlling the fill rate of materials as well as controlling the rise rate of the plunger. This design allows for an even fill on both sides, simultaneously. The rise rate of the plunger is controlled by the Speed Control Knob located on the front panel (Figure 6).

*Note: The fill rate must exceed the plunger rise rate or you will not completely fill the syringe.*

## Adjustments to the Dispensing Valve

Model 828 dispensing valves are preset before shipment. If adjustment is needed, please refer to the Model 828 Dispensing Valve User Guide. This manual is included in your shipment.

# Reloading System Material

1. Remove the Air Line from the Cartridge Retainer.
2. Using a wrench, remove the Fill Tubing from the Cartridge End Fitting.
3. Install a filled Cartridge Retainer.

*Note: To minimize air pockets when reloading, push down on the cartridge piston until material is at the cartridge fitting end and then install the cartridge retainer.*

## Replacing the Fill Tubing

1. Remove the Tubing Retainer Cover. This can be done by removing the Allen cap screws that hold it in place (Figure 7).
2. Pull out the Fill Tubing and install new tubing.

*Note: Refer to steps in the “Installing Fill Tubing” section of this manual for further details.*

**Figure 7. Replace the Fill Tubing**

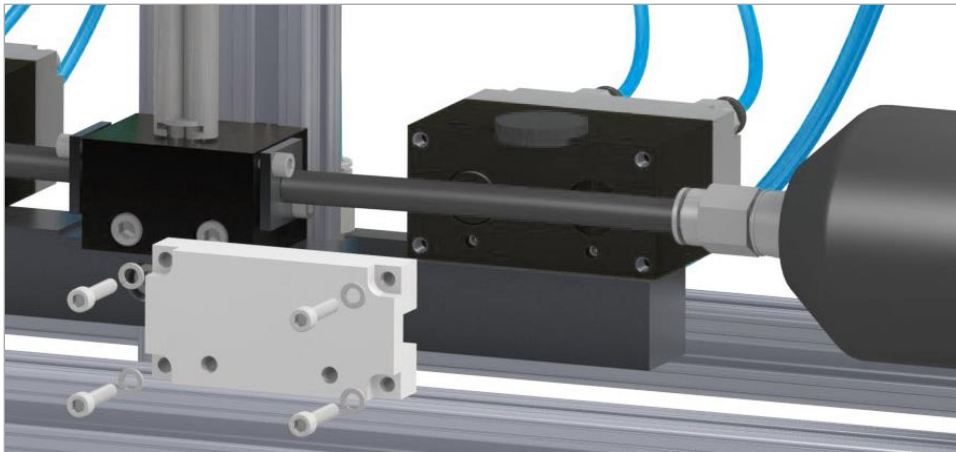

## Spare Parts and Accessories

Item	Part Number
<b>Air Regulator</b>	
Precision Air Regulator	T14051
<b>Dispensing Valve</b>	
Model 828 Dispensing Valve	T17057
<b>Material Reservoirs</b>	
Cartridge Reservoir, 20 oz (500 mL)	T16763
Cartridge Reservoir, 32 oz (900 mL)	T17035
<b>Tubing</b>	
Fluid Line Kit, 3/8" OD Black Polyethylene	T16787
Air Line Kit	T16789
<b>Miscellaneous</b>	
Footswitch	T14999
Power Cord, 110 VAC, 7 ft	T17021

# Specifications

## System Specifications

### Materials of Construction—Wetted Parts

Dispensing valve = See Model 828 dispensing valve user guide

Fluid tubing = light-blocking, black, polyethylene

Fluid tubing fittings = acetal

### Operating Specifications

Required air pressure = 60-80 psi (0.41-0.55 MPa), 50 micron filtered, non-lubricated; dry air

Required Electrical Power = 120 VAC, 50/60 Hz

### Dimensions

System Dimensions: 29.125 in x 24.125 in x 18.25 in [73.98 cm x 61.28 cm x 46.36 cm] (W x H x D)

**Figure 8. Model 1200 Dimensional Diagram**

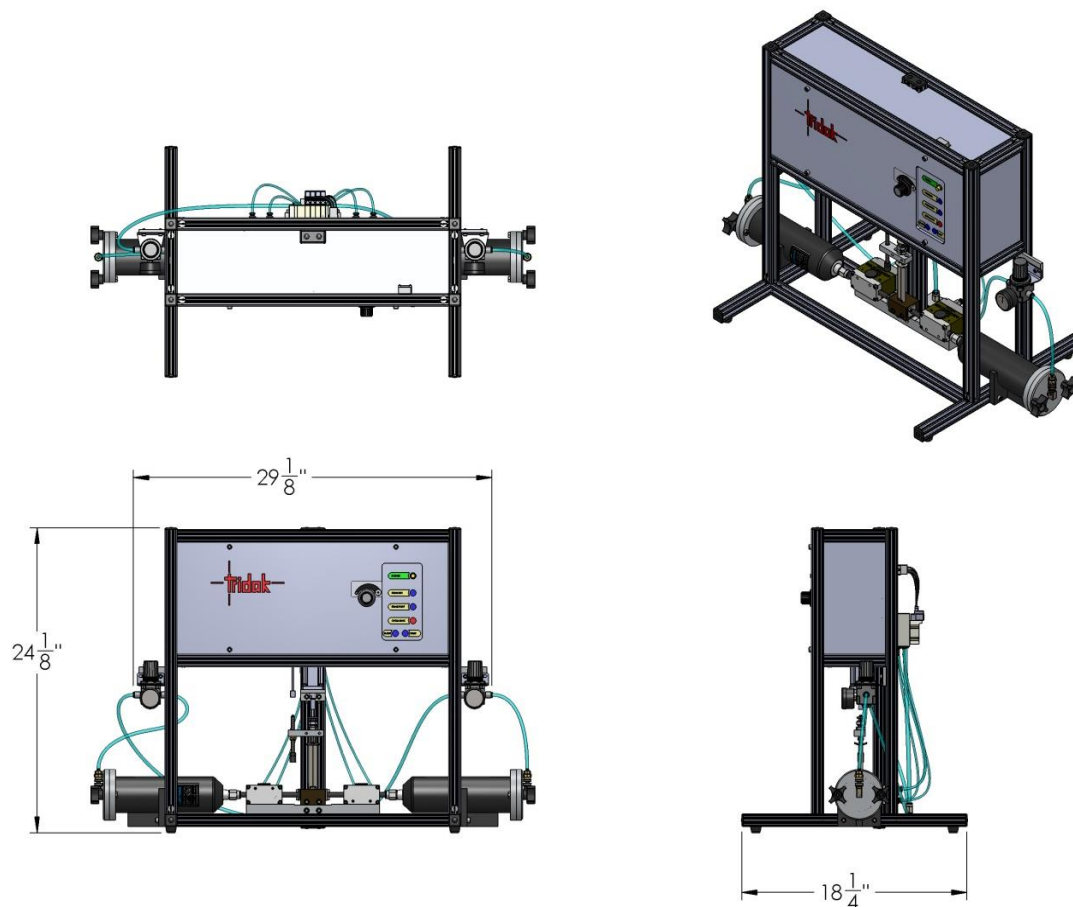

# Warranty

From date of purchase, Dymax offers a one-year warranty against defects in material and workmanship on all system components with proof of purchase and purchase date. Unauthorized repair, modification, or improper use of equipment may void your warranty benefits. The use of aftermarket replacement parts not supplied or approved by Dymax, will void any effective warranties and may result in damage to the equipment.

***IMPORTANT NOTE: DYMAX RESERVES THE RIGHT TO INVALIDATE ANY WARRANTIES, EXPRESSED OR IMPLIED, DUE TO ANY REPAIRS PERFORMED OR ATTEMPTED ON DYMAX EQUIPMENT WITHOUT WRITTEN AUTHORIZATION FROM TRIDAK. THOSE CORRECTIVE ACTIONS LISTED ABOVE ARE LIMITED TO THIS AUTHORIZATION.***

# Index

- Accessories, 12
- Air Connections, 8
- Assembly, 6
  - Utilities, 7
- Components, 6
- Compressed Air Requirements, 7
- Contact Information, 4
- Description of System Components, 6
- Dimensions, 13
- Dispensing Valve Adjustments, 11
- Documentation
  - Other Documentation Included, 4
- Electrical Requirements, 7
- Fill Height Adjustment, 10
- Flow Mode, 11
- Fluid Connections, 8
- Help, 4
- Installing Fill Tubing, 8
- Modes of Operation, 11
- Operation, 11
- Optional Equipment, 12
- Parts Included, 7
- Product Overview, 5
- Pump Mode, 11
- Reloading Material, 11
- Replacing the Fill Tubing, 12
- Safety, 4
  - Personal Protective Equipment, 5
  - Preventing Injection Injury, 5
  - Using Safe Operating Pressures, 5
- Setup, 6
- Spare Parts, 12
- Specifications, 13
- Speed Control Adjustments, 11
- Support, 4
- System Benefits, 5
- System Features, 5
- System Preparation, 7
  - Cartridge Retainer Preparation, 7
  - Install Fill Tubing, 8
  - System Interconnect, 8
- System Priming, 9
- Unpacking, 6
- Utilities, 7
- Warranty, 14



© 2013-2020 Dymax Corporation. All rights reserved. All trademarks in this guide, except where noted, are the property of, or used under license by Dymax Corporation, U.S.A.

Please note that most filling and repackaging system applications are unique. Dymax does not warrant the fitness of the product for the intended application. Any warranty applicable to the product, its application and use is strictly limited to that contained in Dymax's standard Conditions of Sale. Dymax recommends that any intended application be evaluated and tested by the user to insure that desired performance criteria are satisfied. Dymax is willing to assist users in their performance testing and evaluation. Data sheets are available for pressure pots upon request.

T17566 MAN046 4/9/2020

**Dymax Corporation**

+1.860.482.1010 | info@dymax.com | [www.dymax.com](http://www.dymax.com)

**Dymax Europe GmbH**

+49 611.962.7900 | info\_de@dymax.com | [www.dymax.de](http://www.dymax.de)

**Dymax Engineering Adhesives Ireland Ltd.**

+353 21.237.3016 | info\_ie@dymax.com | [www.dymax.ie](http://www.dymax.ie)

**Dymax Oligomers & Coatings**

+1.860.626.7006 | info\_oc@dymax.com | [www.dymax-oc.com](http://www.dymax-oc.com)

**Dymax UV Adhesives & Equipment (Shanghai) Co. Ltd.**

+86.21.37285759 | dymaxasia@dymax.com | [www.dymax.com.cn](http://www.dymax.com.cn)

**Dymax UV Adhesives & Equipment (Shenzhen) Co. Ltd.**

+86.755.83485759 | dymaxasia@dymax.com | [www.dymax.com.cn](http://www.dymax.com.cn)

**Dymax Asia (H.K.) Limited**

+852.2460.7038 | dymaxasia@dymax.com | [www.dymax.com.cn](http://www.dymax.com.cn)

**Dymax Asia Pacific Pte. Ltd.**

+65.6752.2887 | info\_ap@dymax.com | [www.dymax-ap.com](http://www.dymax-ap.com)

**Dymax Korea LLC**

+82.2.784.3434 | info\_kr@dymax.com | [www.dymax.com/kr](http://www.dymax.com/kr)